

## MODEL RD48

4-7/8" Center Distance

30/1 or 45/1 Ratio

Torque Rating\*:

30,000 in-lb operating

90,000 in-lb ultimate

Dimensional interchange to Braden WR30

# Application Information

- Hub City Boom Rotation drives are specifically designed for swing boom drives on digger derricks, truck mounted cranes and aerial devices. They can also be used as winch drives and conveyor drives on intermittent duty applications.
- Ratios shown are common industry standards. Other ratios are available. Consult the factory for ratio options.
- Units are supplied with a machined pilot diameter at the output flange, which must be supported by a close fitted hole in the customers' mounting arrangement.
- High ratio units tend not to back drive, however, they are not guaranteed to be self-locking, external brakes should be utilized if back driving must be prevented.
- Torque values given are maximum operating torque values assuming the low speed input and intermittent and variable nature of rotation drive loading.
- Ratings shown are average ratings for preliminary selection only. Exact rating may vary with ratio and output pinion configuration.
- Hub City recommends thorough testing in the actual loading conditions prior to final selection.

# *Modified & Custom Capability*

- *External pinions – The most common pinions are shown. Other pinions are available.*
- *Input Flanges – Boom Rotation Drives are typically driven with a hydraulic motor. Units can be provided with a variety of NEMA motor flanges or an input shaft.*
- *Mounting Flanges – Hub City can provide custom mounting capability to match your existing template.*
- *Winch Drives – Boom rotation drives can be modified to operate as winch drives.*
- *Other Utility Applications – If you have looked through this brochure and do not see exactly what you need, Hub City has the resources and the engineering expertise to design and produce a custom drive. Capabilities range from flange and shaft modifications to custom housing dimensions.*

**Consult the factory or your Hub City representative  
with your specifications!**



*A REGAL-BELOIT Company*

*“At the Heart of What Drives Your World”*

**2914 Industrial Avenue ▪ P.O. Box 1089 ▪ Aberdeen, SD 57402**

**Phone: (605) 225-0360 ▪ Fax: (605) 225-0567**

**Email: [sales@hubcityinc.com](mailto:sales@hubcityinc.com) ▪ [www.hubcityinc.com](http://www.hubcityinc.com)**



## **BOOM ROTATION GEAR DRIVES FOR UTILITY VEHICLES**



*“At the Heart of What Drives Your World”*

# Features

Hub City, Inc. offers a series of worm gear speed reducers specifically designed for rotation drives. These reducers, ranging in size from 2-5/8" center distance to 4-7/8" center distance have the following features in common:

- Ductile iron gear case for high shock resistance.
- Mounting flange integral to gear case for increased stability and strength.
- Heavy duty output bearing package offering high stability and high overhung load capability.
- Case carburized integral output shaft and spur gear for high shock resistance. Configurations to meet customer requirements.
- High strength bronze output gear with splined interface to output shaft.
- Hardened and ground worms
- SAE A-2 hydraulic input with 1" round keyed bore is standard, 1" 6B spline is optional.
- Factory filled with EP lubricant for lifetime lubrication.
- Optional eccentric ring available.



# Dimensions & Ratings

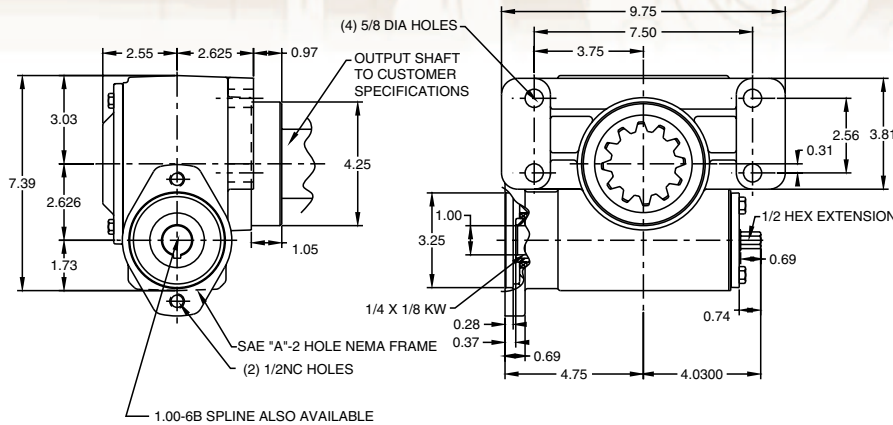

Replaces Ohio Gear RGB-2625.  
Dimensional interchange to Tulsa Winch HFG-430

## MODEL RD26

2-5/8" Center Distance

30/1 Ratio

Torque Rating\*:

6,000 in-lb operating

18,000 in-lb ultimate

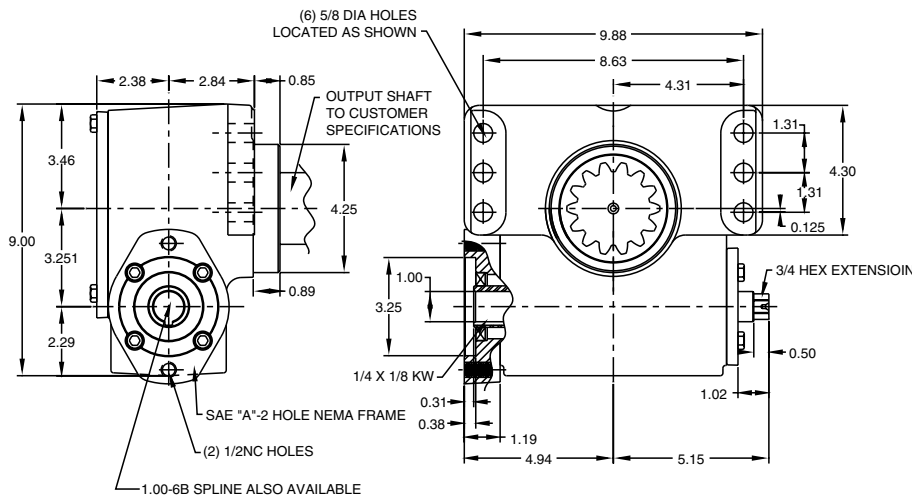

## MODEL RD32

3-1/4" Center Distance

30/1 Ratio

Torque Rating\*:

8,000 in-lb operating

24,000 in-lb ultimate

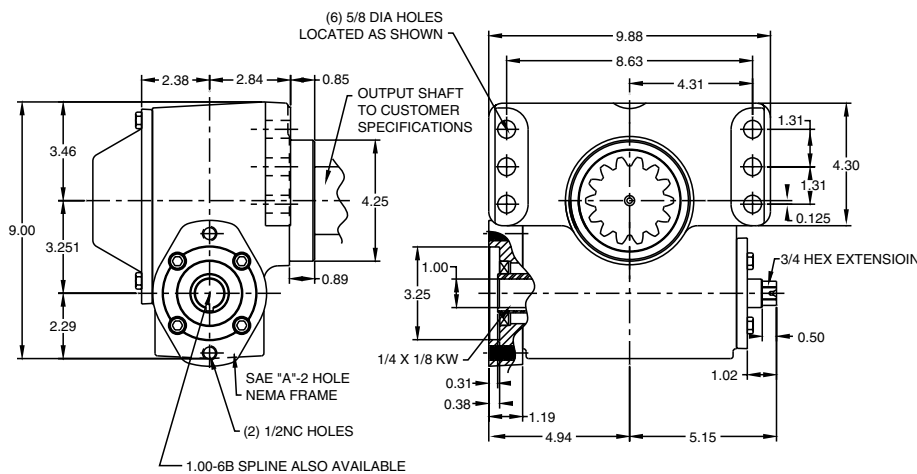

## MODEL RD32C

3-1/4" Center Distance

30/1 Ratio

With integral slip clutch

Torque Rating\* adjustable  
to 8,000 in-lb

\*Torque values given are maximum operating torque values assuming the low speed input and intermittent and variable nature of rotation drive loading. Ratings shown are average ratings for preliminary selection only. Exact rating may vary with ratio and output pinion configuration. Hub City recommends thorough testing in the actual loading conditions prior to final selection.

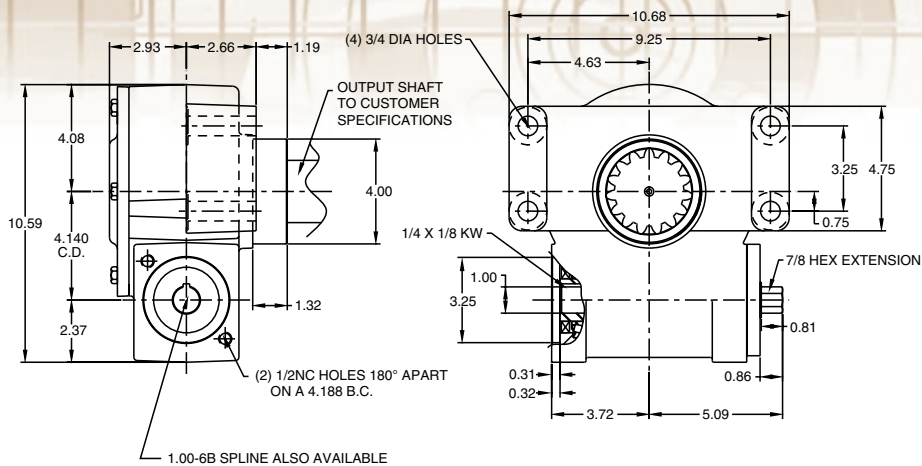

## MODEL RD41

4.14" Center Distance

38/1 Ratio

Torque Rating\*:

13,000 in-lb operating

39,000 in-lb ultimate

Dimensional interchange to Tulsa Winch HFG-938D

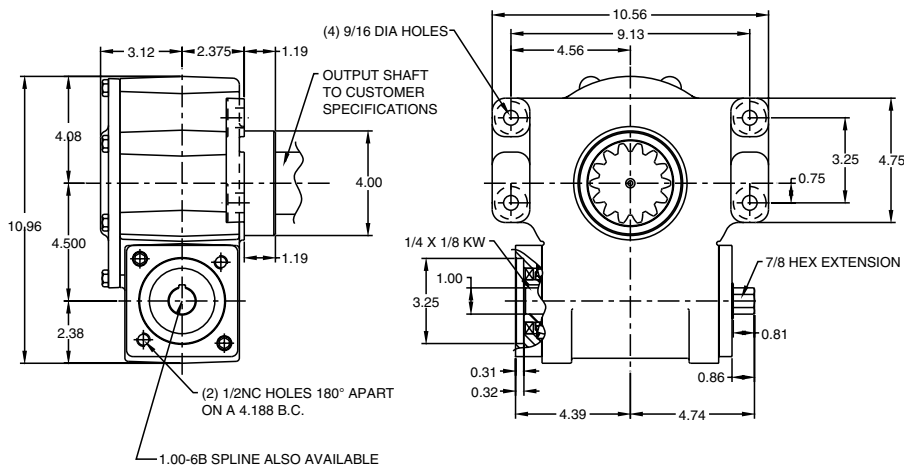

## MODEL RD45

4-1/2" Center Distance

34/1 Ratio

Torque Rating\*:

20,000 in-lb operating

60,000 in-lb ultimate

Replaces Ohio Gear RGB-4500.  
Similar to Tulsa Winch G9

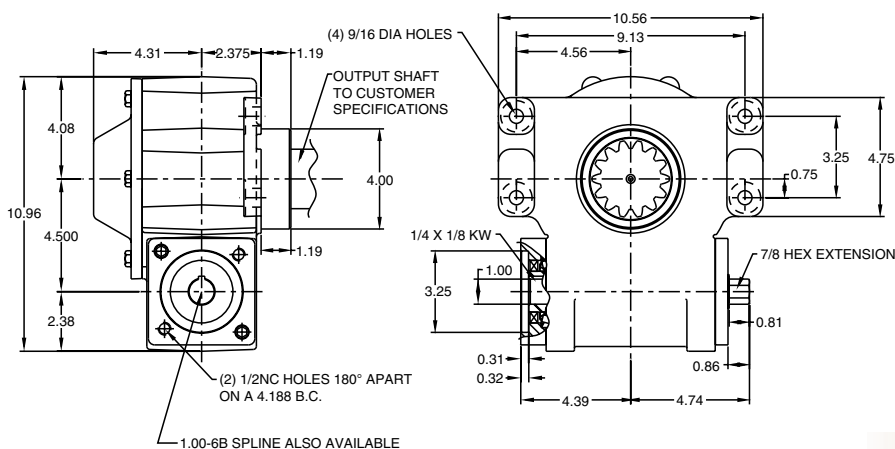

## MODEL RD45C

4-1/2" Center Distance

34/1 Ratio

With integral slip clutch

Torque Rating\*:

Adjustable to 20,000 in-lb

\*Torque values given are maximum operating torque values assuming the low speed input and intermittent and variable nature of rotation drive loading. Ratings shown are average ratings for preliminary selection only. Exact rating may vary with ratio and output pinion configuration. Hub City recommends thorough testing in the actual loading conditions prior to final selection.