

rotor nl[®]

Electric Motors

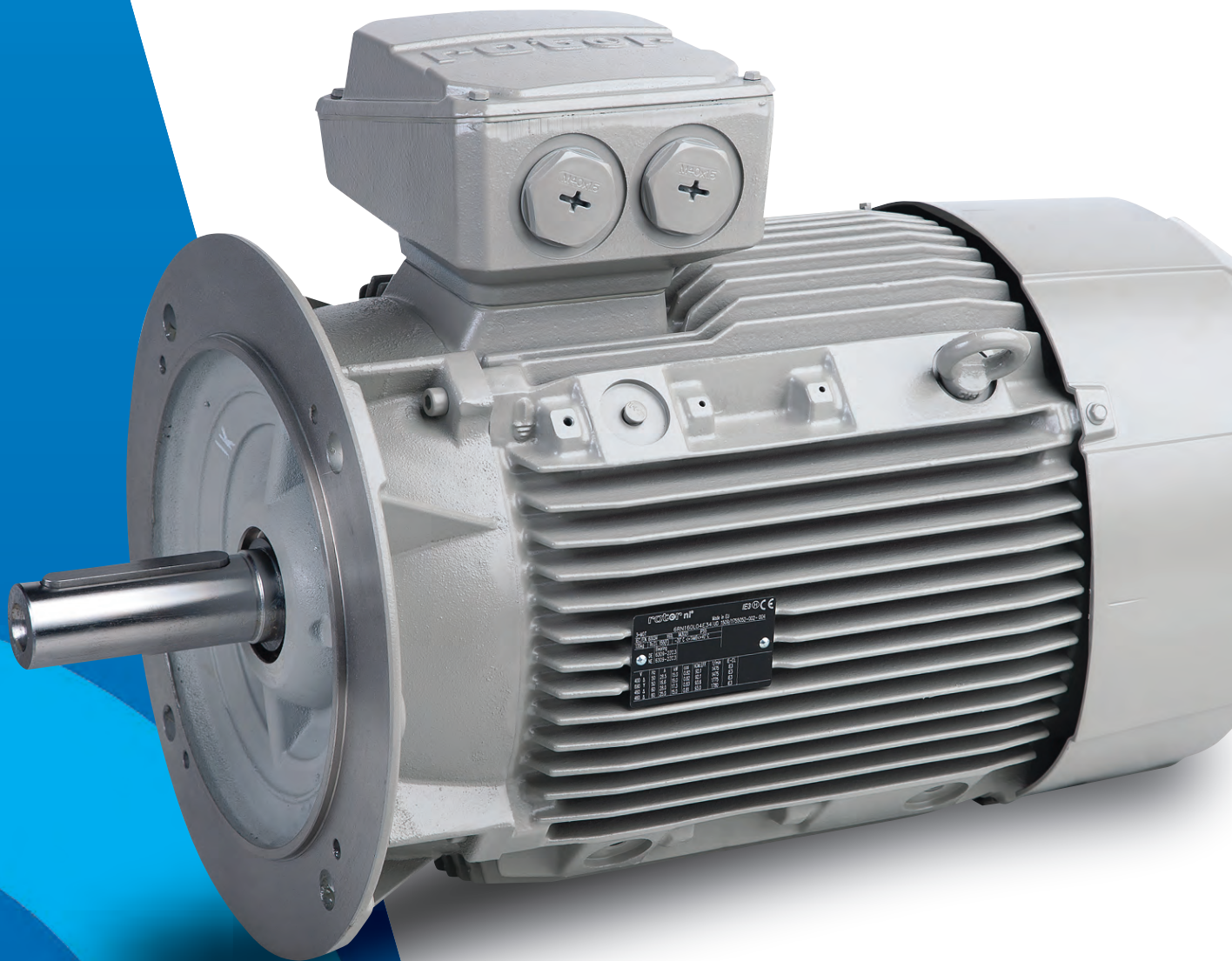

A Regal Brand

REGAL



Rotor B.V.

Mors 1-5
PO Box 45, 7150 AA Eibergen
The Netherlands
Tel. +31 (0)545 - 46 46 40
Fax +31 (0)545 - 47 50 65
info@rotor.nl www.rotor.nl

No motor without Rotor!

This slogan has been long established and with it Rotor BV have been serving the market.

The “rotor nI® electric motors” catalogue is to be used as a practical reference book by both original equipment manufacturers (OEMs) and end users of electric motors.

This catalogue has been structured into five sections:

Section 1. Rotor BV - Regal Beloit

Section 2. Standards and Directives

Section 3. Motor Information

Section 4. Rotor Product Range

Section 5. Rotor BV Services

In addition to the standard electric motor information and our rotor nI® product range, there is also information about the EuP Directive provided and the related IE2 and IE3 standards. This information can be found in Section 2: “Standards and Directives”.

This catalogue has been prepared with great care. Should any errors, omissions or inaccuracies be found, please contact us in due course so corrections can be made in future editions.

We hope that this catalogue will provide an insight view in electric motors and the future development in the market and highlight diversity of our product range. Please feel free to contact us with any questions about our products or services you may have.

We will be happy to assist you!

Table of Contents

Section 1: Rotor BV - Regal Beloit

Rotor nI® Service partners	6
Rotor BV history	7
Regal Beloit Corporation	8
Our People Make the Difference	8
Our Core Values	9
Company Initiatives	9

Section 2: Standards and Directives

Standard Electric Motors	12
Standards and European Directives	12
New IE2 Directives	13
Life Cycle Costs	14
ATEX Motors	16
Euro-Voltage	17

Section 3: Electric motor information

Rotor nI® Name Plate	20
Basic Description of the Electric Motor	22
Fixed or Variable Speed	23
Power and Duty Cycle	24
Maximum Overall Dimensions	26
Mounting Positions and Standardization	27
Degree of Protection IP	28
Insulation Class	29
Motor Thermal Protection	30
Motor Cooling	32
Sound Pressure Level	33
Pole-changing Electric Motors	34
Voltage/Frequency Inverter	35
Pulse Generators and Tachometers	35
Connection Diagrams	36
Bearing Designs and SPM Bearing Monitoring	37
Mechanical Vibrations & Balancing	38
Bearing Load, Service Life and Lubrication	39
Combination of Frame Size, Dimensions and Power	40
Flange and Shaft Dimensions	41
Dimensional Drawings of RN+RNN Series 3-phase Electric Motors	42
Single-phase Electric Motor Dimensions	44

Section 4: Rotor Product Range

RN Series 3-phase Motor Electric Data	46
Standard line 3-phase Electric Motors with Increased Power/Extended Stator Pack	48
Single-phase Electric Motors RCC and RC	49
Marine Applications	50
Offshore Applications	51
Marine & Offshore	52
Shipping Classification Bureaus	53
Explosive atmospheres	55
Category and area classification	55
Coding for Electric Motors in Gas Explosive Atmospheres	55
ATEX Ex-d(e) Pressure Tight Electric Motors	56
ATEX Ex-e Increased Safety Electric Motors	58
ATEX Ex-nA Non-sparking Electric Motors	59
Category and Area Classification for Dust Atmospheres (dust)	62
Coding for Electric Motors in Dust Explosive Area	62
Motor Execution Options	63
Pole-changing Motors Electrical Data	64
Brake Motors and Backstop	68

Section 5: Rotor BV Services

Maintenance and Operating Instructions	70
Bearings and Lubrication	71
Stock Colours and Coating	73
Rotor nI® Products Delivery Schedule	74
Advice and Training	74
Technical Training Courses	74

Section 1

Rotor BV - Regal Beloit



6	Rotor.nl® Service Partners
7	Rotor BV history
8	Regal Beloit Corporation
8	Our People Make the Difference
9	Our Core Values
9	Our Business Initiatives



An insight information about our company can be found in the following paragraphs. Its history, the present days and the future.

Rotor has an extensive, branched network of service partners in the Netherlands. Thanks to our service partners, we are able to serve our customers quickly and efficiently. Our service partners include:

Eriks B.V.

James Wattstraat 19
8912 AS LEEUWARDEN
Tel: 058 215 05 87
Fax: 058 215 85 16
Leeuwarden@eriks.nl
www.eriksservicecenter.nl
24-hour service: 072 514 15 14

Mennes & Jager Elektrotechniek B.V.

Rigaweg 17
9723 TE GRONINGEN
Tel: 050 542 08 00
Fax: 050 541 48 51
info@mennes-jager.nl
www.mennes-jager.nl
24-hour service: 050 542 08 00

Julo Wikkelbedrijf B.V.

Marssteden 47
7547 TE ENSCHEDE
Tel: 053 432 40 75
Fax: 053 431 11 04
info@julobv.nl
www.julobv.nl
24-hour service: 053 432 40 75

Duursma Aandrijftechniek B.V.

Aadijk 33
7602 PP ALMELO
Tel: 0546 54 20 88
Fax: 0546 82 87 09
info@duursma.nl
www.duursma.nl
24-hour service: 055 522 47 00

Visser ZWB Elektromotoren

Benjamin Franklinstraat 27
8013 NC ZWOLLE
Tel: 038 460 08 93
Fax: 038 460 05 47
info@visser-zwb.nl
www.visser-zwb.nl
24-hour service: 038 460 08 93

Elektromotoren Emmen B.V.

Willem Schoutenstraat 13
7825 VV EMMEN
Tel: 0591 61 69 28
Fax: 0591 64 31 54
info@elektromotorenemmen.nl
www.elektromotorenemmen.nl
24-hour service: 06 270 953 97

EMRI Repair B.V.

Morsestraat 10
6716 AH EDE GLD
Tel: 0318 62 04 27
Fax: 0318 63 46 15
info@emri.nl
www.emri.nl
24-hour service: 0318 62 04 27

Van Steen B.V.

Bijsterhuizen Noord 20-04
6604 LJ WIJCHEN
Tel: 024 366 88 66
Fax: 024 645 20 13
info@vansteenbv.nl
www.vansteenbv.nl
24-hour service: 024 366 88 66

Honderslo Elektromotoren

Industrieweg 25
7102 DX WINTERSWIJK
Tel: 0543 51 20 96
Fax: 084 74 58 308
info@hondersloelektromotoren.nl
www.hondersloelektromotoren.nl
24-hour service: 0543 51 20 96

Demri B.V.

Fabriekstraat 39 01
7005 AP DOETINCHEM
Tel: 0314 32 37 53
Fax: 0314 34 36 18
demri@demri.nl
www.demri.nl
24-hour service: 0314 32 37 53

Vos Techniek

Koningslijn 6
7312 GG APELDOORN
Tel: 055 357 88 22
Fax: 055 355 97 98
info@vostechniek.nl
www.vostechniek.nl
24-hour service: 055 357 88 22

Facta Products B.V.

Westerwerf 11
1910 AA UITGEEST
Tel: 0251 36 12 00
Fax: 0251 31 54 03
info@facta.nl
www.facta.nl
24-hour service: 0251 36 12 00

Fremo Wikkeltechniek B.V.

Oostelijke Randweg 2A
1723 LH NOORDSCHARWOUDE
Tel: 0226 31 66 64
Fax: 0226 31 60 32
info@fremo.nl
www.fremo.nl
24-hour service: 0226 31 66 64

V.o.F. Elektromotorenbedrijf, De Vier

Slijperweg 15
1032 KT AMSTERDAM
Tel: 020 636 04 07
Fax: 020 634 20 05
info@elektromotorendevier.nl
www.elektromotorendevier.nl
24-hour service: 020 636 04 07

Wikkelbedrijf Boer & Bakker B.V.

Coenecoop 750 b
2741 PW WADDINXVEEN
Tel: 0182 61 21 15
Fax: 0182 63 17 93
info@boerenbakker.nl
www.boerenbakker.nl
24-hour service: 06 12 73 96 00

Prent Aandrijftechniek B.V.

Leeghwaterstraat 23
3316 EC DORDRECHT
Tel: 078 617 90 75
Fax: 078 618 49 92
td@prent.nl
www.prent.nl
24-hour service: 06 12 99 38 91

Vos Rotating Zevenhuizen B.V.

Nijverheidscentrum 18
2761 JP ZEVENHUIZEN ZH
Tel: 0180 63 75 75
Fax: 0180 63 75 70
zevenhuizen@vosrotating.com
www.vos-rotating.com
24-hour service: 06 48 87 42 05

Istimewa B.V.

Istimewa Elektro
4380 AA Vlissingen
Tel: 0113 612 840
Fax: 0113 613 137
info@istimewa.nl
www.istimewa-elektro.nl
24-hour service: 0113 61 28 40

Van Zelst Elektromotoren B.V.

Raadhuisstraat 14
5161 BH SPRANGCAPELLE
Tel: 0416 27 34 08
Fax: 0416 28 07 87
info@vanzelst.nl
www.vanzelst.nl
24-hour service: 0416 27 34 08

De Bruyn B.V.

Van Konijnenburgweg 105
4612 PL BERGEN OP ZOOM
Tel: 0164 23 43 02
Fax: 0164 25 51 40
info@de-bruyn.nl
www.de-bruyn.nl
24-hour service: 06 48 27 00 74

Wikkelbedrijf Venrooij

Leembaan 62
5753 CV DEURNE
Tel: 0493 32 10 81
Fax: 0493 32 10 63
wikkelbedrijf.venrooij@planet
24-hour service: 0493 32 10 81

Electro Eindhoven

Hoogstraat 349 A
5654 NC EINDHOVEN
Tel: 040 251 98 00
Fax: 040 252 48 70
info@electroeindhoven.nl
www.electroeindhoven.nl
24-hour service: 040 251 98 00

Gekas & Boot Zuid B.V.

Pannenweg 208
6031 RK NEDERWEERT
Tel: 0495 63 41 41
Fax: 0495 63 27 03
nederweert@gekassenboot.nl
www.gekassenboot.nl
24-hour service: 0495 63 41 41

MAINTENANCE PARTNERS EZN BV

Graanmolen 22
6229 PA MAASTRICHT
Tel: 043 36 11 018
Fax: 043 36 10 618
info@eznbv.nl
www.eznbv.nl
24-hour service: 06 54 76 63 25

Wikkelbedrijf Henk Antes B.V.

Buizerdweg 1
6374 BS LANDGRAAF
Tel: 045 531 72 64
Fax: 045 532 63 00
info@antes.nl
www.antes.nl
24-hour service: 06 50 24 36 70

Steenhuis-Peters Groep

Van Neckstraat 5-7
9601 GW HOOGEZAND
Tel: 0598 39 23 21
Fax: 0598 38 03 02
info@biesheuvelgroep.org
www.biesheuvelgroep.nl
24-hour service: 0598 39 32 21



1958 - The Foundation

Rotor BV was founded in 1958 in the Hague, the Netherlands. Its founder Mr Th. M. Kraakman began to import MEZ electric motors from former Czechoslovakia. At the time he was seeing a growing market for standard electric motors. Significant increase in sales and inventory required more space than the then current location could provide. Lack of local opportunities to grow the business and shortage of (skilled) staff ultimately compelled the company to relocate.

1974 - The Relocation

Rotor BV relocated to Eibergen in 1974. The foundation was laid down for the manufacturing of special electric motors. So the rotor nI® electric motor brand was born! The electrical and mechanical properties of rotor nI® electric motors have been tailored for specific applications and operating conditions such as the marine, offshore and petrochemical industries. The electric motor industry is generally placing increasingly higher standards on standard electric motors in terms of efficiency, noise level, maintenance etc. That was the reason for Rotor BV to decide to manufacture electric motors.

1983 - The Expansion

The first pilon was erected in 1983 to begin construction of the new manufacturing hall of an approximate size of 4,000 m². Rotor BV has grown into a company of 80 employees and the factory compound is in its size larger than four football grounds with thousands of electric motors in stock.

1997 - Rotor Belgium

To further strengthen its international footprint, Rotor BV opened a sales office in Gent-Drongen, Belgium in April 1997. Since January 2008 is this location continued under the name Rotec Motors and Gears BVBA, under the management of M. Dhoedt. All Rotor clients in Belgium, Luxembourg and France could, from then on, rely on this branch for all their technical and commercial needs.

2004 - Rotor expands to the UK: Rotor UK

In May 2004 Rotor BV acquired the operation and employees of the Electric Motors Division of Exico Limited in Wellingborough, UK. The company was renamed Rotor (UK) Limited and continued to market electric motors under the management of

J. Hodek, the director of Exico Limited, Electric Motors Division since 1991. With this acquisition Rotor BV could substantially increase its market share in the United Kingdom and become a visible player in the international arena. Rotor BV can since provide better and faster services to its existing British customers.

2005 - Introduction of the rotor nI® ATEX Explosion-proof Electric Motors

Electric motors for explosive atmospheres are available in 3RD and 4RD series in accordance with CENELEC EN 50014, EN 50018, EN 50019 standards (IEC 79-0, IEC 79-1). Rotor BV is an ATEX-certified company. It is the first company of its kind to develop an electric motor drive technology that meets the requirements of the EU ATmosphere EXplosives Directive (ATEX Directive 94/9/EC).

2005 - Implementation of the new ERP system

On 1st October 2005 Rotor BV migrated to a new ERP system, "Microsoft Dynamics Business Solution". The implementation of the new ERP system has further contributed to increasing productivity.

2006 - Management Buy-out at Rotor BV in Eibergen

The current management of Rotor BV and their shareholders have reached an agreement on the management buy-out effective on 1st January 2006. The buy-out has given a new impetus to the continuity and growth of Rotor BV.

2007 - New Facility For The Production Lines

In order to keep up with the steady growth of sales (> 50% between 2004-2006) our new production facility has become a reality. These new production lines enabled a further growth so Rotor continue to meet its customers' needs.

2010 - Acquisition by Regal Beloit Corporation

Rotor BV shares were acquired by an American company Regal Beloit (RBC) in September 2010. The acquisition enabled RBC to grow their market share in Europe and Rotor BV unlocked new opportunities under the leadership of the strong American parent company. The acquisition has been a stimulus for the further growth and development of Rotor BV!

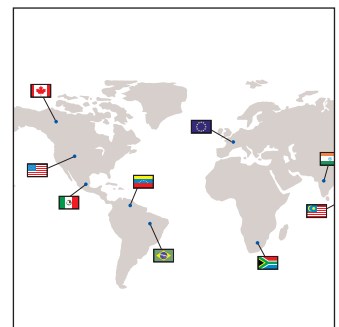

A Regal Brand

REGAL

Rotor BV joined the American electrical group Regal Beloit Corporation (RBC) In September 2010.

Regal Beloit is a leading manufacturer of electrical and mechanical motion control and power generation products serving markets throughout the world. Regal Beloit products can be found in a vast variety of applications that virtually affect every aspect of life.

A relatively unknown brand, Regal Beloit stands at the forefront of some well-known brands such as Leeson, Marathon Motors, GE Commercial Motors, CMG, etc. Through these brands, RBC has gained a substantial market share and 3.5 billion-plus in turnover worldwide, thereby turning RBC into a major player in the electrical market. All brands represented by RBC have the same characteristics, and deliver the same level of excellence in terms of quality and reliability.



The extensive range of solutions reflects the slogan that Regal Beloit products are ***“at the heart of what drives our world”***.

Our People Make the Difference

In our main location in Eibergen as well as in the other locations in the EU you will find professional and dedicated staff working closely together to meet our customers' needs and requirements! Our service is not just limited to shipping the products on order out on time but through communication with the customer we provide solutions not just products!

We believe that the lines of communication in our organisation are short, allowing us to serve the market quickly and always find the correct solution for all our customers effectively. Our employees' years of experience and their commitment to help and serve have earned Rotor the loyalty of their customers!

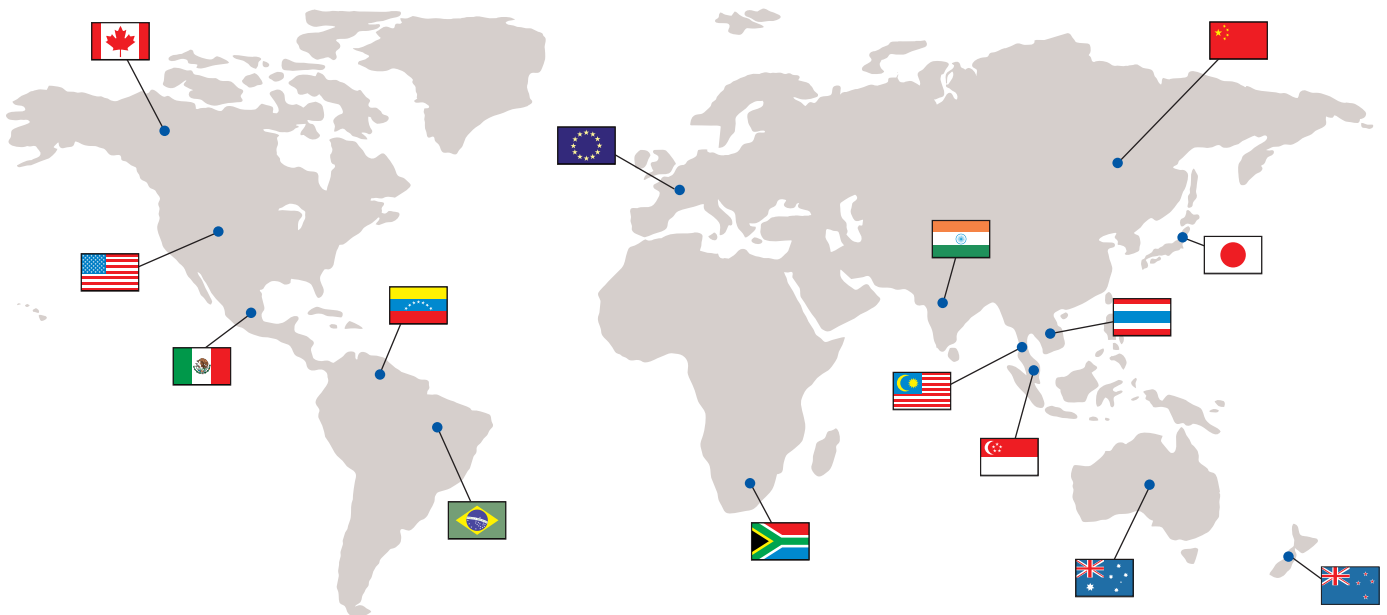

Our Core Values

We convert power into motion to help the world run more efficiently.

Integrity

We are a company that is honest, trustworthy, candid, transparent and fair.

High Energy

Our culture promotes a strong work ethic with high energy teams fostering a culture of inclusion and respect for all.

Performance

Everyone is expected to perform and our stakeholders count on us to execute, meet commitments and continuously improve.



9

Company Initiatives:

Customer Care

Our future depends on the success of our customers. We will establish closer relationships with our customers, actively listen to their feedback and respond with a sense of urgency.

Globalization

We want to be global for three reasons. First, we want to participate in high growth markets around the world. Second, many of our customers are global and we want to serve customers where they do business. Finally, we want to utilize our global capabilities to seek out the best talent and to remain globally competitive.

Innovation

We will build the future of the Company on products that are new and needed. We accept that with an innovation headset comes a certain degree of risk and we are committed to investing in new products, technologies and processes that deliver real value to our customers.

Sustainability

The long term sustainability of our Company requires not only continuous growth and profitability but also that we take personal responsibility for the impact we have on our planet and for the fair and just treatment of the people we employ.

Simplification

Complexity is a serious disadvantage in business. We aim to simplify every aspect of our operations to eliminate complexities in order to increase our speed, improve our flexibility and reduce our costs.



A Regal Brand

REGAL

Section 2

Standards and Directives

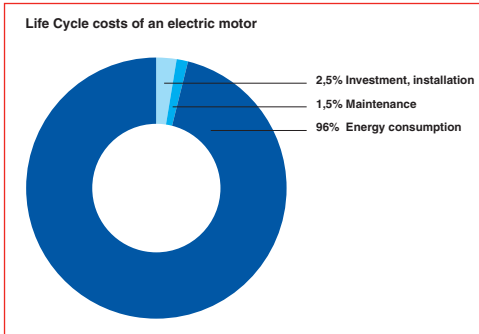

12	Standard Electric Motors
12	Standards and European Directives
13	New IE2 Directives
14	Life Cycle Costs
16	ATEX Motors
17	Euro-Voltage

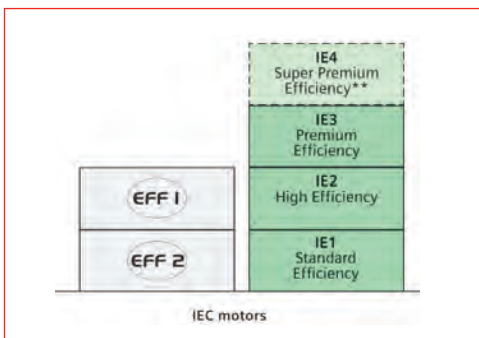
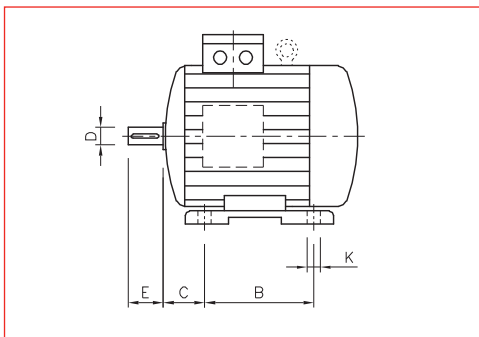

The following pages contain information about the new standards and guidelines of rotor nI® motors comply with and a comprehensive description of ATEX motors.

Standard Electric Motors

It may not be quite clear which standard(s) are applicable when a reference is being made to “standard electric motors”. The designer of a driven equipment always aims at the highest level of exchangeability for all components but often incorrectly assumes that any “standard electric motor” can always be replaced with another “standard electric motor” made by a different manufacturer without a problem.

The most important construction features are defined in the EN 50 347 standard, which specifies the frame size (distance from the floor to the shaft centre in mm) and the mounting dimensions of the feet and their position in relation to the shaft

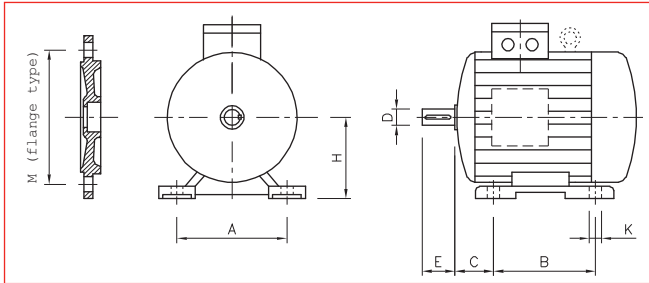

as well as the shaft key sizes, flange sizes and flange fitting dimensions (see figure 1). The standard however does not specify the other motor dimensions such as the motor length, the the position and the size of the terminal box, or the motor frame sizes in relation to all power outputs.

The relation between the motor frame sizes and power outputs as well as the shaft and flange sizes are specified in the EN 50 347 standard for single speed electric motors. rotor nI® electric motors fully comply with this standard and all motor combinations can be supplied accordingly.

Additionally rotor nI® Increased Output Electric Motors can be supplied. These motors have higher power output when compared with Power Output/Frame Size combinations specified in the standard. The Increased Output Motors additional to the standard motors specified in the standard are clearly indicated in the Rotor standard documentation and/or applicable Price List.

Please be informed that the standard does not specify a specific position of the terminal box. The motor manufacturer can therefore decide on a position of the terminal box as “on top”, “on the right” or “on the left” side when viewed from the DE (drive end) of the electric motor. Most electric motor manufacturers prefer to position the terminal box “on top” with the option to rotate the cable entry 4 x 90°.

Standards and European Directives

Standards

All electric motors featured in this catalogue meet the relevant IEC, EN, ISO, DIN and NEN standards. The most important standards are listed in the table below.

European Directives

Rotor nI® electric motors meet all European Directives and have CE mark displayed.

EC manufacturer declaration in accordance with European Directives:

Rotor B.V., Mors 2, 7151 MX Eibergen, the Netherlands, declare under their sole responsibility that the product (electric motors) marked as rotor nI®, RN series and any derived executions to which this declaration applies are in conformity with the relevant harmonized standards:

in accordance with the provisions of the European Directives: 73/23/EEC Council Directive on the harmonization of the laws of Member States relating to Electrical Equipment designed for use within certain voltage limits as amended by Council Directive 93/68/EEC;

89/336/EEC Council Directive on the approximation of the laws of the Member States relating to electromagnetic compatibility as amended by Council Directive 91/263/EEC, Council Directive 92/31/EEC and Council Directive 93/68/EEC;

98/37/EG Council Directive on the approximation of the laws of the Member States relating to machinery. We would like to point out that the product is intended to be installed in a machine where the machine may only be commissioned after it has been brought in line in accordance with the European criteria based on the MACHINERY Directive.

The Netherlands, Eibergen, June 16, 2011.

Description	EN-IEC	ISO	DIN
Nominal operation and properties	IEC 60034-1		
Protection degrees	IEC 60034-5		DIN 40050
Cooling method	IEC 60034-6		
Construction forms	IEC 60034-7		
Turning direction and marking on connection terminals	IEC 60034-8		
Maximum noise production	IEC 60034-9		
Connection voltage	IEC 60038		
Dimensions, tolerances	EN 50347		
Balancing		ISO 2373	DIN 45665
Energy Efficiency	IEC 60034-30		

New IE2 Directives

Electric motors are clearly the largest consumers of electricity in the European Union. With approximately 680 TWh of electricity consumption per year, they account for up to 59% of the total power generation. Thanks to the directives stipulating ecological design and the implementation of energy labelling, electric motors can save up to 135 TWh/year* (a consumption reduction of nearly 20%).

Classification of Electric Motors

The former CEMEP voluntary EU agreement (CEMEP is the European Committee of Manufactures of Electrical Machines and Power Electronics) has been replaced by the EuP Directive, which must be implemented in the national legislation in all member states of the European Union. It classifies the following three levels of energy efficiency:

- IE1—standard efficiency;
- IE2—high efficiency;
- IE3—premium efficiency.

IE stands for International Efficiency. The new IE coding replaces the former EFF1 and EFF2 classifications. The relationship between the different efficiency classifications is shown in Figure 1. The new EuP Directive applies to:

- 2 to 6—pole electric motors
- with a nominal U_N voltage of up to 1,000 V
- a nominal P_N power between 0.75 kW and 375 kW
- classified on the basis of continuous operation (S1)

Figure 1: Comparison of standards

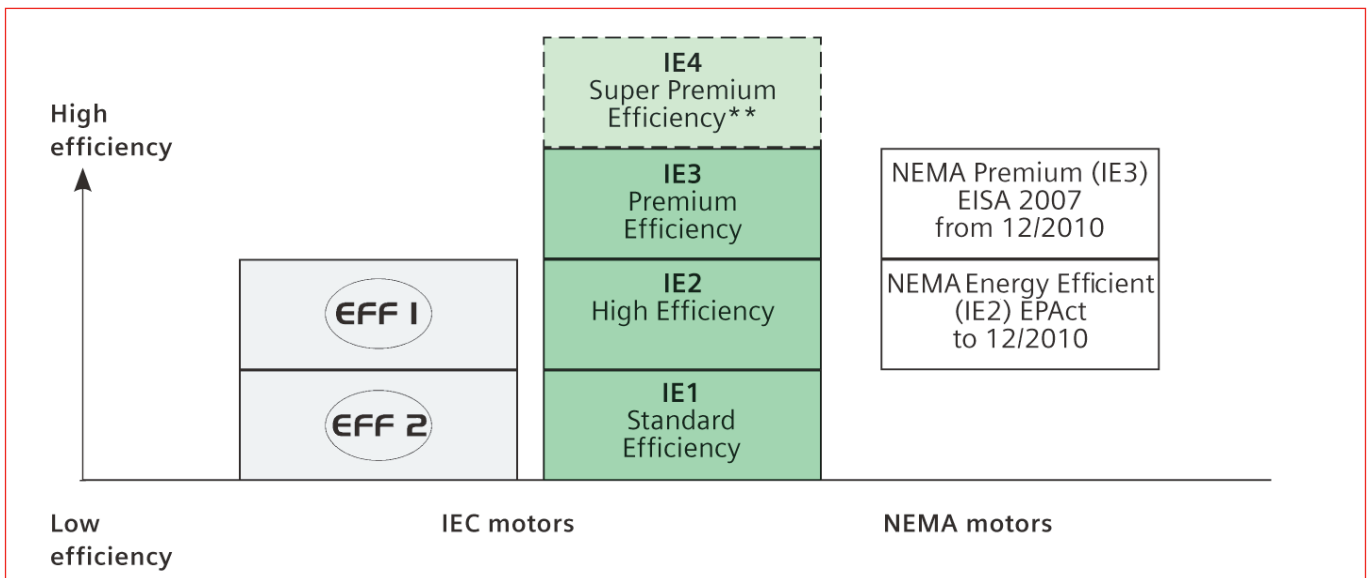

* TWh = TerraWatt Hour. One TWh is equal to one billion KiloWatt Hours.

** IE4: under development.

Life Cycle Costs

During the electric motor life-cycle, the operating costs are determined mainly by the energy costs. These are 95% to 99% of the total cost of the electric motor during its life-cycle.

Besides the better energy efficiency the IE2 and IE3 electric motors provide also other benefits:

- The higher efficiency results in less less heat needed to be dissipated so a smaller fans are used.
- The smaller fans result in less ventilation losses and a reduction of noise level.
- The other benefit is the lower motor temperature as it is a direct result of the improved electric motor design, making IE2 and IE3 electric motors suitable for applications with ambient temperatures exceeding 40°C.

Life Cycle costs of an electric motor

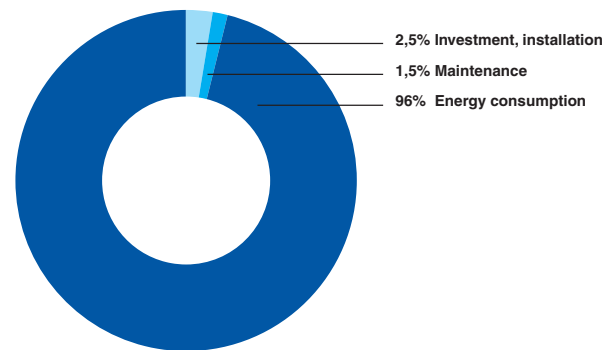

The new Directive ensures that only improved design motors are placed on the market, which means that the IE1 motors (formerly EFF2) became the lowest efficiency limit, the old EFF3 efficiency class completely eliminated and the new more efficient “premium efficiency” IE3 motors will supersede the current standard of “high efficiency” IE2 motors (formerly EFF1).

The efficiency of IE3 electric motors is higher than that of lower class electric motors such as IE2 (EFF1) and IE1 (EFF2) electric motors.

Please note that the greater the power output of an electric motor the higher the efficiency and the smaller the differences in efficiency between the individual classes (IE1, IE2, IE3). See Figure 2.

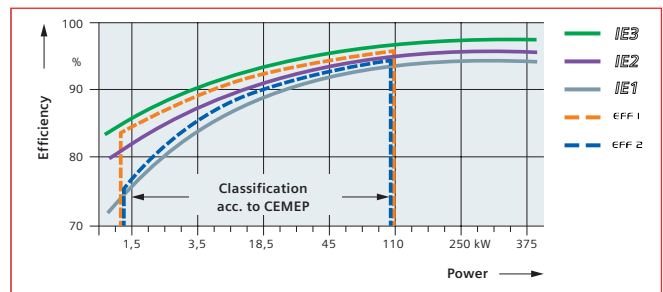

Figure 2: Classification of electric motors 0.75-375 kW according to IE labels.

The main changes between the former CEMEP agreement and the new EUP Directive standard are shown schematically in the figure below.

	CEMEP voluntary EU agreement	NEMA EPAct	EuP Directive based on the standard IEC 60034-30 (EuP Directive still has to be passed; EuP = Energy Using Product)
Description	Voluntary agreement between the EU Commission and the European Committee of Manufactures of Electrical Machines and Power Electronics CEMEP	The current legislation in the US/CAN/MX also regulates efficiency	The EuP Directive must be implemented in national legislation in all European Countries. IEC 60034-2-1 is the basis for determining losses and therefore determining the efficiency.
Number of poles	2, 4	2, 4, 6	2, 4, 6
Power range	1.1-90 kW	0.75-150 kW	0.75-375 kW
Level	Standard — EFF3 Improved efficiency — EFF2 High efficiency — EFF1	High Efficiency NEMA Premium	Standard Efficiency — IE1 High Efficiency — IE2 Premium Efficiency — IE3
Voltage	400 V, 50 Hz	230/460 V, 60 Hz	< 1,000 V, 50/60 Hz
Degree of protection	IP5X	Open + enclosed motors (IP23 + IP56)	All
Motors with brake	NO	YES	Being harmonised
Geared motors	NO	NO	YES
Explosion-proof motors	NO	YES	EuP Directive — being harmonised IEC 60034-30 — YES (however, explosion protection always has the higher priority)
Validity	Voluntary agreement; this will be withdrawn when national implementation comes into effect	From 12/2010 NEMA Premium (IE3) minimum efficiency	Standard IEC 60034-30, valid since October 2008, EuP (measures still have to be finally passed), legal transition period is then 36 months.

What does the new standard mean for Rotor and for you?

As from 1st June 2011 Rotor is longer able to supply 5RN electric motors that do not meet the criteria set out in the new EuP standard. The new 6RN electric motors will replace the old range. The new 6RN electric motors contain more copper and other materials in order to reduce energy losses and improve electric motor efficiency. The 6RN electric motors meet the new IE2 standard.

The 6RN electric motors are being marketed at higher prices to reflect the additional material used.

Because of the higher efficiency of the 6RN electric motors, the capital cost payback period is shorter.

EuP Directive implementation dates

16th June 2011: All new manufactured electric motors must be of the IE2 efficiency standard or higher

1st January 2015: Electric motors with the nominal power output of 7.5kW to 375 kW must be of the IE3 efficiency standard (IE2 motors can be used for a frequency inverter duty)

1st January 2017: Electric motors with the nominal power output of 0.75kW to 375 kW must be of the IE3 efficiency standard (IE2 motors can be used for a frequency inverter duty)

If you have any question concerning the new standards and the consequences for your company, please contact our Contact Centre at +31 (0)545-464640.

ATEX is an abbreviation for the French “ATmosphère EXplosible” and is used as a synonym for the two European Directives related to explosion hazard in atmospheric conditions.

The ATEX legislation directives:

- ATEX 95 directive specifies **the construction** of equipment and protection systems intended for use in potentially explosive atmospheres
- ATEX 137 directive specifies **the use** of equipment and protection systems intended for use in potentially explosive atmospheres.

The designations for both directives are:

Directive	Old number	New number	Application
94/9/EC	ATEX 100A	ATEX 95	for manufacturers
1999/92/EC	ATEX 118	ATEX 137	for equipment users

ATEX Directive 95

This directive sets out the essential health and safety requirements (EHSR) for equipment and protection systems intended for use in potentially explosive atmospheres.

Classification in Groups

The relevant equipment and protection systems are classified into two groups.

Group I: intended for underground use (mining industry).

Group II: intended for use in other locations with potentially explosive atmospheres.

Within these groups, different categories define the level of protection.

Group I: contains two protection categories, M1 and M2.

Group II: contains three protection categories, 1 through to 3.

The categories definition: The lower the number, the higher is the protection level.

ATEX Directive 137

ATEX Directive 137 is actually an addendum to ATEX Directive 95. ATEX Directive 95 describes the construction of equipment intended for installation and use in potentially explosive atmospheres and ATEX Directive 137 describes how these areas should be classified into hazardous areas and how work can be performed safely in these areas.

Classification in hazardous areas

The environmental atmosphere and prevailing conditions at the workplace are a major determinant for the installation methods of equipment and the choice of materials to be used. It is therefore a prerequisite to classify the areas with potentially gas and dust explosive atmospheres into hazardous areas.

The potentially hazardous areas are classified into hazardous areas based on the frequency and duration of the occurrence of an explosive atmosphere:

Area 0, 1 and 2: areas at risk of gas explosion (where a mixture of air with any combination of flammable gas, fumes or mist is present)

Area 20, 21 and 22: areas at risk of dust explosion (where a cloud of flammable dust may occur).

The lowest number indicates the most hazardous area.

The higher is the classification of the hazardous area, the more stringent requirements are specified for the environment and the application and use of the equipment and the protection systems.

* Source: Euronorm.net

The IEC 38 “standard voltages” standard (Sixth edition) was published in 1983. This standard specifies the standard voltages for the electricity network, the equipment and the installations. The NEN 10 038 standard, “Electrical power systems and equipment—Nominal voltages” was published in the Netherlands in 1989 and includes the IEC 38 standard without changes. This standard makes provisions for a “standard voltage” of 3 x 230V/400V—50Hz. The implementation of this standard denominated the same voltage in a large area in order to ensure minimum variations of voltages in variety of products and equipment.

More about tolerances

The supply network voltage tolerances during the operation have been defined in national standards such as NEN 3173 where a distinction has been made between zone A and zone B.

A voltage tolerance of $\pm 5\%$ applies in zone A and $\pm 10\%$ in zone B. An electrical rotating machine shall be capable of performing its primary function within zone A but need not to comply with its performance at the rated voltage and the rated frequency and may, therefore, exhibit some deviations. The motor temperature rise may be higher than at rated voltage and rated frequency.

An electrical rotating machine shall be capable of performing its primary function within zone B but need not to comply with its performance at the rated voltage and the rated frequency and may, therefore, exhibit some deviations. The deviations may be higher than in zone A. The motor temperature rise may be higher than at rated voltage and rated frequency. The temperature rise in zone B may be higher than in zone A. Extended operation at the perimeter of zone B is not recommended.

rotor nI® electric motors

The rotor nI® electric motors are supplied as 3 x 400V—50Hz (Y or D) as standard. Other voltages are available upon request. The voltage for which the electric motor has been designed is always specified on the rating plate of any electric motor.

- 1 230V between a phase and neutral and 400V between any two phases in a three-phase system.
- 2 This means that the nominal torque (Nm) of the electric motor is maintained.
- 3 The temperature rise limits or temperature limits in

accordance with this standard apply at the rating point and may be progressively exceeded as the operating point moves away from the rating point. For conditions t the extreme boundaries of zone A, the temperature rises and temperatures typically exceed the limits specified in this standard by approximately 10K.

- 4 In practical applications and operating conditions, a machine will sometimes be required to operate outside the perimeter of zone A. Such excursions should be limited in value, duration and frequency of occurrence. Corrective measures should be taken, where practical, within a reasonable time, for example, a reduction in output. Such action may avoid a reduction in machine life from temperature effects.

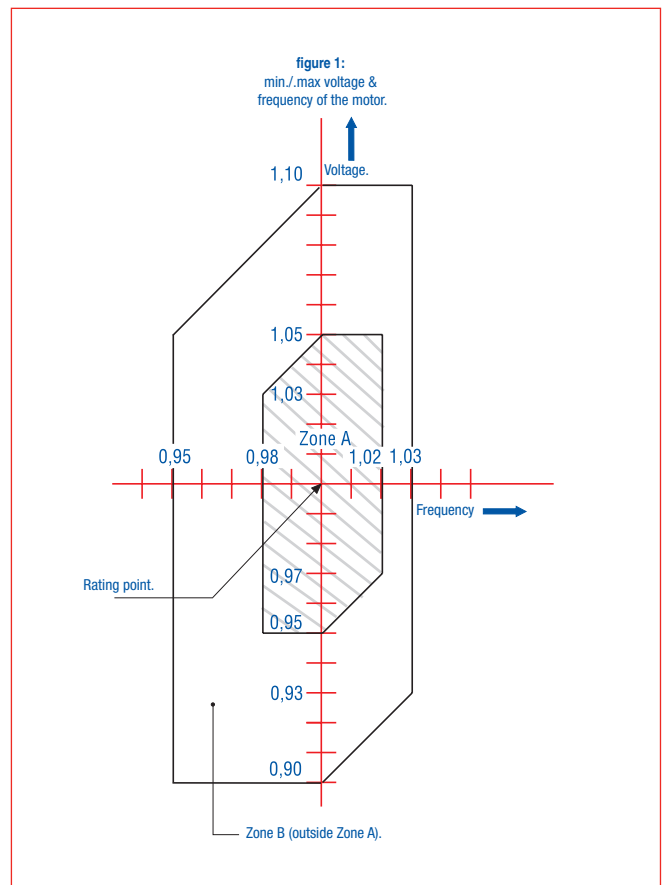

Section 3

Electric motor information

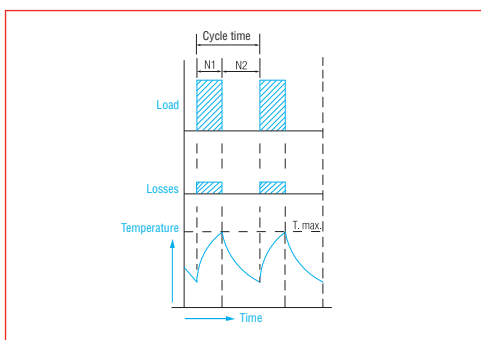
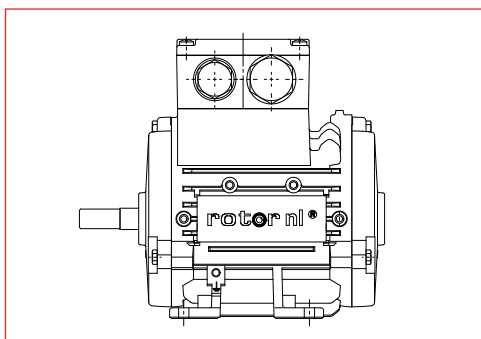
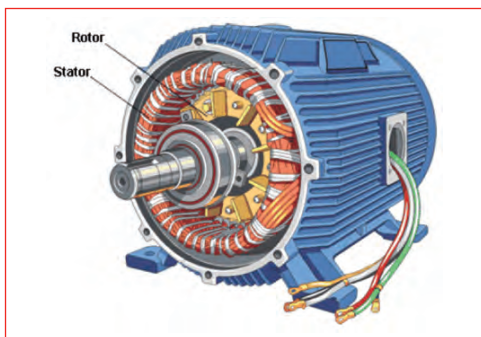

20	Rotor ni® Name Plate
22	Basic Description of the Electric Motor
23	Fixed or Variable Speed
24	Power and Duty cycle
26	Maximum Overall Dimensions
27	Mounting Positions and Standardisation
28	Degree of Protection IP
29	Insulation Class
30	Motor Thermal Protection
32	Motor Cooling
33	Sound Pressure Level
34	Pole-changing Electric Motors
35	Voltage/Frequency Inverter
35	Pulse Generators and Tachometers
36	Connection Diagrams
37	Bearing Designs and SPM Bearing Monitoring
38	Mechanical Vibrations & Balancing
39	Bearing Load, Service Life and Lubrication
40	Combination of Frame Size, Dimensions and Power
41	Flange and Shaft Dimensions
42	Dimensional Drawings of RN + RNN Series 3-phase Electric Motors
44	Single-phase Electric Motor Dimensions

On the following pages you will find everything you need to know about rotor ni® electric motors, including the frame size, dimensions and outputs.

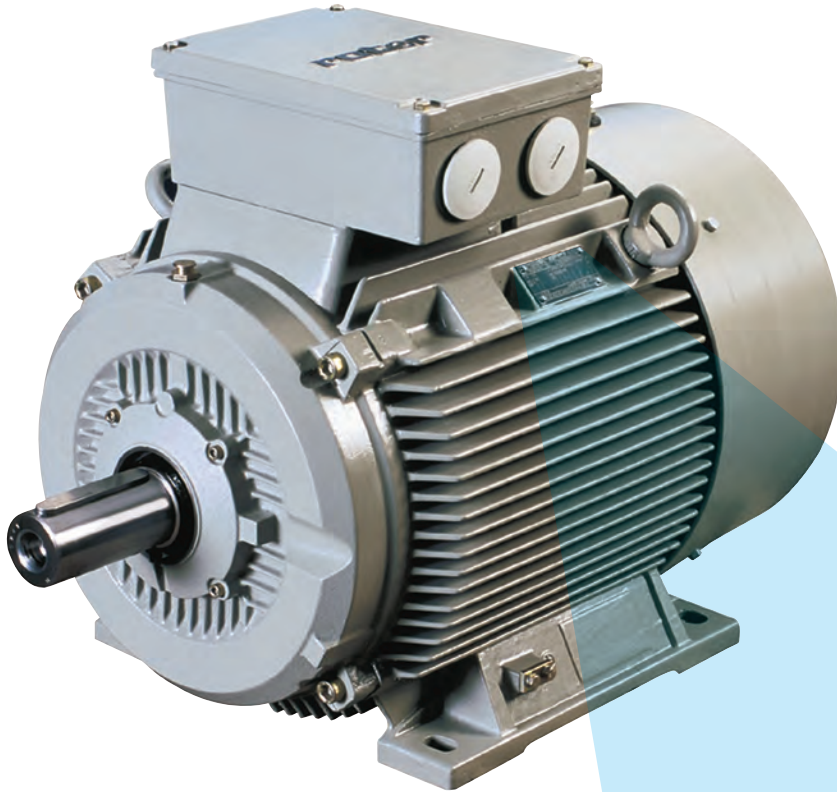

rotor nl® 3~Mot. IEC/EN 60034 IE2 
RRT-1105/#1340421-003-005 6RNA112M04E22 IC411 Eff 86,6%
4 kW S1 IP55 IM3041 FF215
 Δ/Y 400/690 V 50Hz 8,23/4,75A
cos φ 0,8 1461 min⁻¹
ThCl F 29 kg
Half

Description on rating plate	Description	Page
6RNA112M04	Serial name: frame size; number of poles	15
IC411	Cooling type	32
IP55	Protection class	28
IM3041	Construction form / mounting	27
FT-215	Flange pitch circle diameter	41
50 Hz	Supply frequency	23
Δ/Y 400/690V	Connection + supply voltage	36
4 kW	Power	24
8,23/4,75 A	Current at 400/690 volt	33
1461 min ⁻¹	Speed	23
S1	Operational type	24
Marine design	Special model	52

Basic Description of the Electric Motor

An electric motor is a commonly used device that transforms electrical energy into mechanical energy through the interaction of magnetic fields. The main two components of an electric motor are the stator and the rotor.

There is a copper windings in the stator, which when energised creates a rotating magnetic field, which induces electric current in the rotor cage. This creates a magnetic field in the rotor and it is the interaction of the two magnetic fields, which makes the rotor to rotate.

The rotating magnetic field of the stator always rotates faster than the rotor. The rotor is not rotating synchronously with the rotating magnetic field in the stator (hence it is an asynchronous electric motor). The speed difference between the rotating magnetic field in the stator and the rotor speed is called 'slip'. It is the slip, which enables voltage to be generated in the rotor cage creating the rotor current. The interaction of the magnetic field in the stator and the magnetic field in the rotor produce the torque which is the mechanical output on the shaft.

Higher shaft load provides more slip, more slip generates more rotor current, more rotor current produces more torque.

This is the typical principle of asynchronous squirrel-cage electric motors.

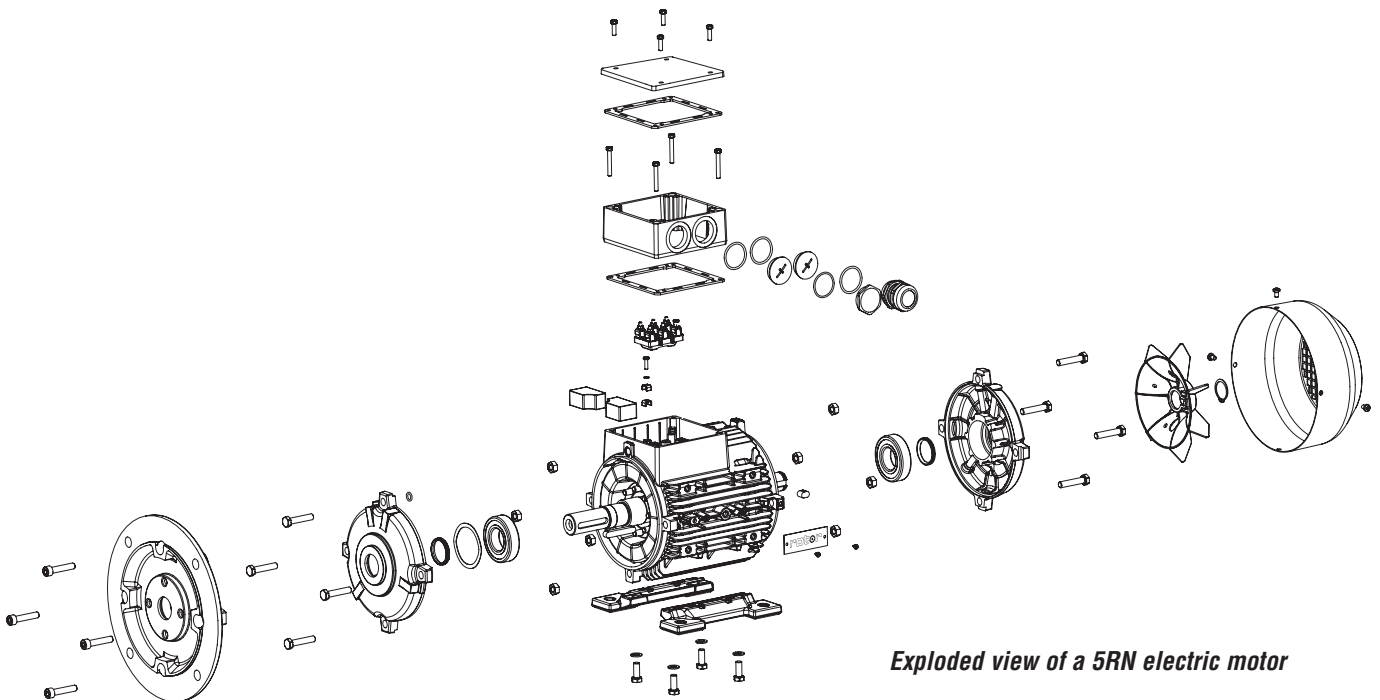
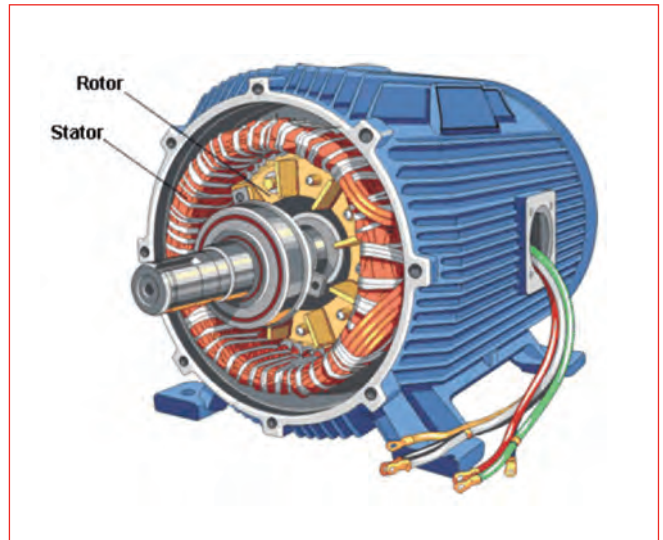

Exploded view of a 5RN electric motor

Fixed or Variable Speed

The rotating speed of an electric motor depends on the number of poles and the frequency of the supply. A single speed electric motor has 2, 4, 6, 8, etc. poles (1, 2, 3 or 4 pole-pairs respectively) and the mains supply frequency is 50Hz or 60 Hz as standard.

The more poles in an electric motor the lower the synchronous speed. The 2-pole electric motor makes 50 revolutions per second which is 3000 rpm and a 4-pole electric motor makes one half which is 1500 rpm at 50Hz.

At 60 Hz a 2-pole electric motor makes 3600 rpm and a 4-pole electric motor 1800 rpm. The following calculation is used to calculate the rotating speed of an electric motor.

The asynchronous motor rotational speed = $\frac{60 \times f \text{ (supply frequency)}}{2p \text{ (pole pairs)}} - \text{slip} = \dots \text{min}^{-1}$

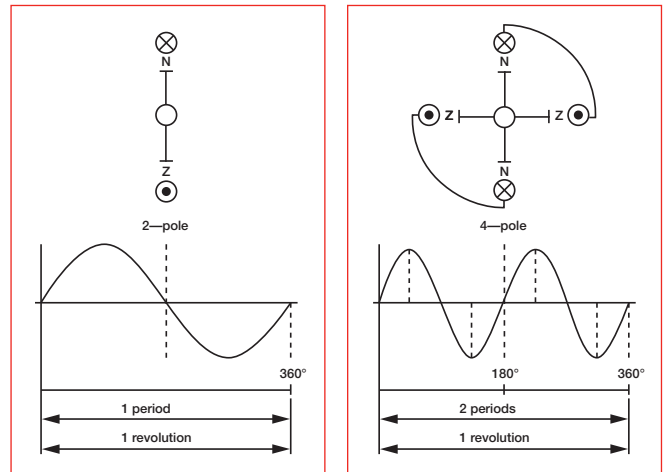

Rotor nl® electric motors can also be supplied as multiple speed motors (pole-changing). These electric motors are provided with a special winding that enable rotating at different speeds.

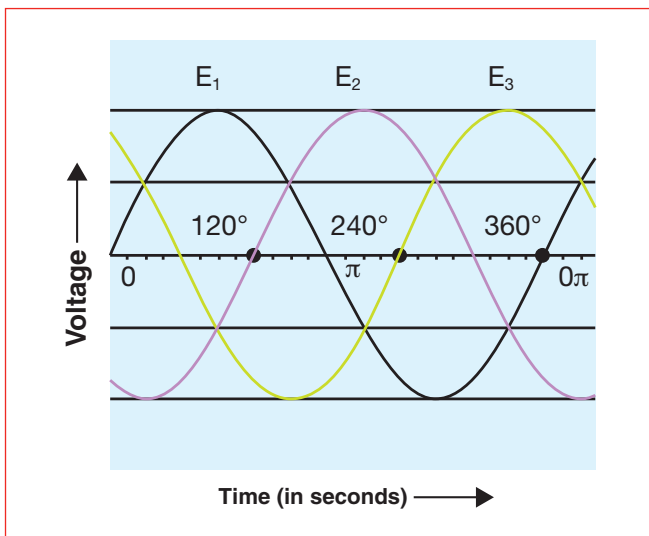

Power and Duty cycle

Power Output

The unit of power output is kW (1HP = 0.75kW; 1 kW = 1.34 HP) (HP ≈ Horse Power). The power output values specified in this catalogue are based on maximum power at continuous load at what the thermal stability of the motor winding is attained. The continuous load is referred to as S1 Duty Cycle. Electric motors can be used at various Duty Cycles, short-term or intermittent (S2, S3, S4, etc.). A higher power output may be achieved whilst used at short-term or intermittent duty. They main factor for determination of the maximum power output at a short-term or intermittent Duty Cycle is the temperature rise, which when added to the (standard) ambient temperature of 40°C must not exceed the limit temperature of the insulation material used in the electric motor winding. In order to achieve the optimum efficiency a correct combination of the size of the motor should be used for the given application.

Duty Types (Duty Cycles)

The Duty Cycles (S1 to S10) have been defined in IEC 60034-1 standard indicating the run cycles of electric motors and in case of the intermittent duty also the frequency of the run periods. The power output limit up to which an electric motor can be utilised is determined by the maximum permissible temperature of the stator winding.

The electrical and mechanical parameters of electric motors are based on Duty Cycle S1 - continuous operation.

Duty Type S1: Continuous duty

Operation with a constant load during such a period of time that a thermal equilibrium is attained. The power that is specified on the rating plate may be taken up continuously. The rating plate specifies: S1.

Duty type S2 - Short-time duty

Operation at constant load for a given time, less than that required to reach thermal equilibrium, followed by a time de-energized and at rest of sufficient duration to re-establish machine temperatures within 2 K of the coolant temperature. The appropriate abbreviation is S2, followed by an indication of the duration of the duty.

Example: S2 60 min (alternative: 5, 10, 20 or 30 min).

Duty type S3 - intermittent periodic duty

A sequence of identical duty cycles, each including a time of operation at constant load and a time de-energized and at rest. In this duty, the cycle is such that the starting current does not significantly affect the temperature rise. The appropriate abbreviation is S3, followed by the cyclic duration factor. Example: S3 25% (alternative: 30, 40 or 60%).

Duty type S4 - Intermittent periodic duty with starting.

A sequence of identical duty cycles, each cycle including a significant starting time, a time of operation at constant load and a time de-energized and at rest. The appropriate abbreviation is S4, followed by the cyclic duration factor, the moment of inertia of the motor (J_M) and the moment of inertia of the load (J_{ext}), both referred to the motor shaft.

Example: S4 25% $J_M = 0.15 \text{ kg x m}^2$ $J_{ext} = 0.7 \text{ kg x m}^2$

Duty type S5 - Intermittent periodic duty with electric braking

A sequence of identical duty cycles, each cycle consisting of a starting time, a time of operation at constant load, a time of electric braking and a time de-energized and at rest. The appropriate abbreviation is S5, followed by the cyclic duration factor, the moment of inertia of the motor (J_M) and the moment of inertia of the load (J_{ext}), both referred to the motor shaft.

Example: S5 25 % $J_M = 0.15 \text{ kg x m}^2$ $J_{ext} = 0.7 \text{ kg x m}^2$

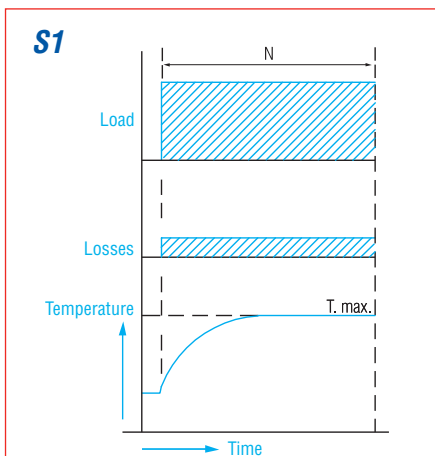

$N = \text{constant load}$
 $T_{max} = \text{highest reached temperature}$

S1: continuous operation
 Operation with a constant load during such a period of time that a thermal equilibrium is attained.

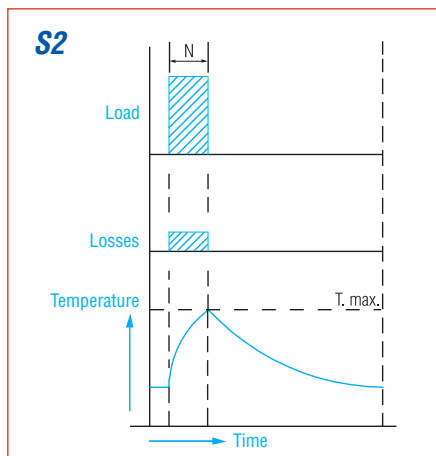

$N = \text{constant load}$
 $T_{max} = \text{highest temperature range during the load}$

S2: brief operation
 Operation with a constant load during a specific period of time that is shorter than the period of time in which the thermal equilibrium would be attained followed by a rest period that is sufficiently long to restore the thermal equilibrium with the coolant.

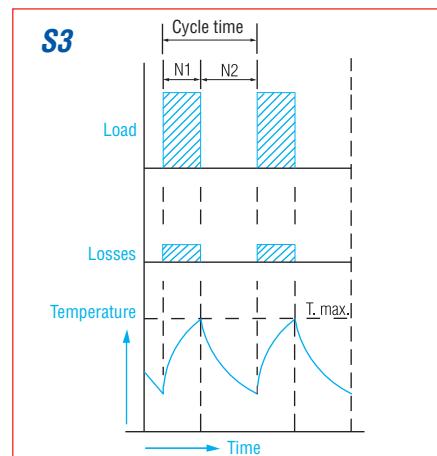

$N1 = \text{constant load}$
 $N2 = \text{rest period}$
 $T_{max} = \text{highest temperature range during a cycle.}$

S3: intermittent regular operation
 Operation composed of a series of equal cycles, each consisting of a period with constant load and a rest period.

Duty type S6 - Continuous duty with intermittent load

A sequence of identical duty cycles, each cycle consisting of a time of operation at constant load and a time of operation at no-load. There is no time de-energized and at rest. The appropriate abbreviation is S6, followed by the cyclic duration factor. Example: S6 40%

Duty type S7 - Continuous-operation periodic duty with electric braking

A sequence of identical duty cycles, each cycle consisting of a starting time, a time of operation at constant load and a time of electric braking. There is no time de-energized and at rest. The appropriate abbreviation is S7, followed by the moment of inertia of the motor (J_M) and the moment of inertia of the toad (J_{ext}), both referred to the motor shaft. Example: S7 $J_M = 0.4 \text{ kg x m}^2$ $J_{ext} = 7.5 \text{ kg x m}^2$

Duty type S8 - Continuous duty with periodic changes in load and rotation

A sequence of identical duty cycles, each cycle consisting of a time of operation at constant load corresponding to a predetermined speed of rotation, followed by one or more times of operation at other constant loads corresponding to different speeds of rotation (carried out, for example, by means of a change in the number of poles in the case of induction motors). There is no time de-energized and at rest. The appropriate abbreviation is S8, followed by the moment of inertia of the motor (J_M) and the moment of inertia of the load (J_{ext}), both referred to the motor shaft, together with the the load, speed and cyclic duration factor for each speed condition. Example: S8 $J_M = 0.5 \text{ kg x m}^2$ $J_{ext} = \text{ kg x m}^2$ 16kW 740rpm 30%; 40kW 1460rpm 30%; 25kW 980rpm 40%

Duty type S9 - Duty with non-periodic load and speed variations

A duty in which generally load and speed vary non-periodically within the permissible operating range. This duty includes frequently applied overloads that may greatly exceed the reference load. The appropriate abbreviation is S9. For this duty type, a constant load appropriately selected and based on duty type S1 is taken as the reference value ("P_{ref}") for the overload concept.

Duty type S10 - Duty with discrete constant loads and speeds

A duty consisting of a specific number of discrete values of load (or equivalent loading) and if applicable, speed, each load/speed combination being maintained for sufficient time to allow the machine to reach thermal equilibrium. The minimum load within a duty cycle may have the value zero (no-load or de-energized and at rest). The appropriate abbreviation is S10, followed by the per unit quantities $p/\Delta t$ for the respective load and its duration and per unit quantity TL for the relative thermal life expectancy of the insulation system. The reference value for the thermal life expectancy is the thermal life expectancy at rating for continuous running duty and permissible limits of temperature rise based on duty type S1. For a time de-energized and-at rest, the load shall be indicated by the letter r. Example: S10 $p/\Delta t = 1.1/0.4; 1/0.3; 0.9/0.2; r/0.1$ TL = 0.6 The value of TL should be rounded off to the nearest multiple of 0.05. For this duty type a constant toad appropriately selected and based on duty type S1 shall be taken as the reference value ("P_{ref}") for the discrete loads.

Diagrams of operational types

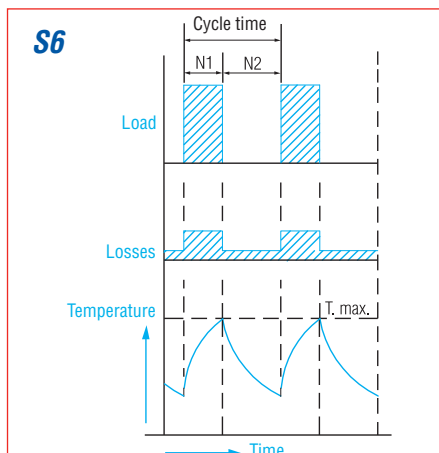

N1 = constant load
N2 = no load
T max = highest temperature range during a cycle

S6: interrupted operation with intermittent load
A series of equal cycles each consisting of a period with a constant load and a period with zero load.

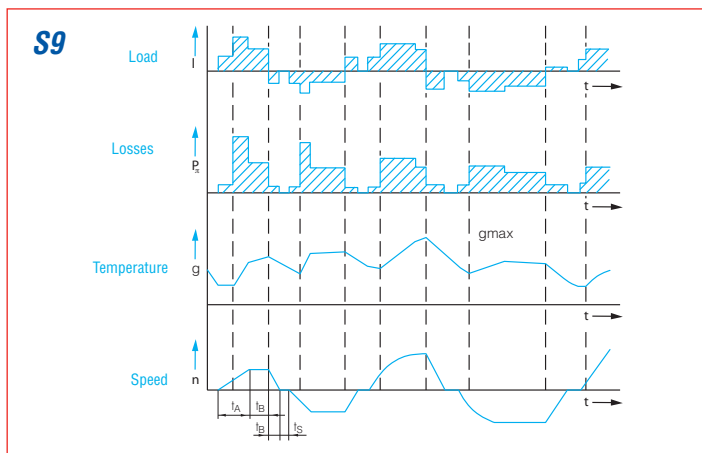

S9: operation with non-regular changing load and rotational speed
Operation where in general the load and the rotational speed do not regularly change within the allowed operational area.

Maximum Overall Dimensions

Standard three-phase electric motors must comply with the standard maximum overall dimensions as specified in the DIN 42 673 standard, page 4.

It is important to keep these maximum overall dimensions in mind when designing the driven equipment so the possibility to replace a standard electric motors with another make is guaranteed where possible. A sufficient space around the electric motor must be maintained to enable motor mounting and connection as well as to enable sufficient air cooling during the operation. The maximum overall dimensions are applicable on all standard three-phase squirrel cage TEFC electric motors. (TEFC ≈ Totally Enclosed Fan Cooled).

The rotor nl® single-phase squirrel cage electric motors are also supplied in accordance with the standard applicable for three-phase electric motors. The frame sizes are the same as the three-phase motors. The total length of single-phase motors may be longer at certain sizes. For more information please see the dimensional drawings contained in this brochure.

IEC/DIN housing size	Size in mm.			
	XA	XB	Y	Z
63	73	110	210	181
71	78	130	224	196
80	96	154	256	214
90S	104	176	286	244
90L	104	176	298	244
100L	122	194	342	266
112M	134	218	372	300
132S	158	232	406	356
132M	158	232	440	356
160M	186	274	542	480
160L	186	274	562	480
180M	206	312	602	554
180L	206	312	632	554
200L	240	382	680	600
225S	270	428	764	675
225M	270	428	764	675
250M	300	462	874	730
280S	332	522	984	792
280M	332	522	1,036	792
315S	372	576	1,050	865
315M	372	576	1,100	865

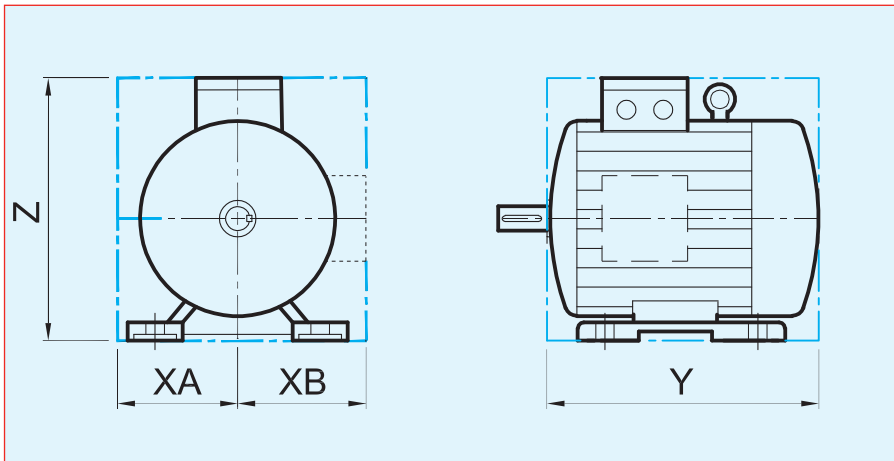

Mounting positions and Standardization

The mounting positions of electric motors are summarised in the table below.

Remarks:

The specified mounting must always be mentioned when ordering an electric motor. The actual motor mounting may influence the protection class and bearing design. Flange-mounted electric motors need further specification of the required pitch circle diameter of the fixing holes in the flange (FF or FT type of flange) (Dimension M).

FF (Flange Free Holes) = free holes are in B5 flanges, FT (Flange Tapped Holes) = tapped holes are in B14 flanges. The pitch circle diameter (dimension M) is specified in the EN

50347 standard in relation to the frame size for the FF (B5) flange and the FT (B14A) flange (up to 160 frame).

The pitch circle diameter (dimension M) is not specified for FT (B14B) flanges the EN 50347 standard, they however are specified in IEC 72-1 standard.

The motor mountings and the positions are summarised in the IM code as per the table below. For detailed information please consult the IEC 34-7 (NEN 10034-7) standard.

1st digit	IM1... foot motor	IM2 ... IM2 foot/flange motor	IM3 ... flange motor
2nd digit	IM10..	IM20..	IM21..
3rd digit	IM 1001 IM B3	IM 2001 IM B35	IM 2101 IM B34
	IM 1011 IM V5	IM 2011 IM V15	IM 2111 IM V15
	IM 1031 IM V6	IM 2031 IM V36	IM 2131 IM V36
4			
	IM 1051 IM B6	IM 2051	IM 2151
	IM 1061 IM B7	IM 2061	IM 2161
	IM 1071	IM 2071	IM 2171
8			
	IM B8		
			IM 3001 IM B5
			IM 3011 IM V1
			IM 3031 IM V3
			IM 3601 IM B14
			IM 3611 IM V18
			IM 3631 IM V19

4th digit
1: 1 standard IEC shaft end
2: 2 shaft ends
3: 1 conical shaft end
4: special shaft end(s)

Degree of Protection IP

The Degree of Protection of rotating electric machines is defined as protection against the penetration of mechanical particles, dust and water. The Degree of Protection is defined in the following standard: IEC 34-5 (NEN-EN 60034-5).

Indicators

The Degree of Protection is indicated by the 'IP' followed by two numbers, the first indicating the protection against mechanical particles and the second indication the protection against water.

An example of the Degree of Protection definition:

IP-55;

The higher the digits, the greater the protection level against mechanical particles/ against water (see the tables below). All rotor nI® three-phase electric motors are supplied in IP55 as standard enabling an outdoor installation. The higher level of protection may however cause a few issues:

- 1. Tight shaft seals cause additional “sliding friction” which generates heat and contributes to the friction losses, which are more significant at fast running motors.
- 2. The condensation drain holes used for draining off the condensation water and the equalisation of the atmospheric pressure (“breathing option”) must be partially enclosed at IP55 and completely enclosed at IP56 protection.







A suitable solution can implemented to overcome the first

problem by fitting an alternative shaft seal in the endshield/flange or the bearing cap but not on the bearing as it would cause excessive heat development. The second problem is less easy to resolve. The probability of condensation water accumulating inside the motor is higher at higher protection levels. A moisture-proof insulation system (tropical insulation is standard in all rotor nI® motors) is usually sufficient for IP55 protection.









At the protection class IP56 the problem is more difficult to overcome, especially for frame size greater than 100 frame as the air volume in large electric motors is larger and this increases the potential for condensation when changes in temperature occur. To minimise condensation accumulation a stable internal temperature must be maintained (5°C above the ambient temperature). This applies for motors when stationary as the internal temperature always rises significantly during the operation. The solution is the installation of anti-condensation (or “standstill”) heaters. See page 31 for more details.

The protection class selection is intended to reduce the probability of electric motor failures due to ingress of mechanical particles and water. This however is not a guarantee of trouble-free operation. Higher protection class should be implemented where necessary and for specific applications as it sometimes can achieve the opposite effect with regard to the reliability of operation. The IP rating displayed on the motor nameplate must be observed during the electric motor installation.

Protection degrees specified by the first indicator

1st	protection against solid particles and dust	
0		No protection
1		Protection against the penetration of solid particles with a diameter larger than 50 mm.
2		Protection against the penetration of solid particles with a diameter larger than 12 mm.
3		Protection against the penetration of solid particles with a diameter larger than 2.5 mm.
4		Protection against the penetration of solid particles with a diameter larger than 1 mm.
5		Limited dustproof. The quantity of dust must not compromise electric motor performance.
6		Protection against the penetration of dust (dustproof)

Protection degrees specified by the second indicator

2nd	protection against water	
0		No special protection
1		Protection against water that falls perpendicularly on to the electric motor
2		Protection against water that falls on the electric motor at an angle of no more than 15°
3		Protection against water that falls on the electric motor at an angle of no more than 60°
4		Protection against splashing water that falls on the electric motor from all sides
5		Protection against water jets (under a specific pressure) from a random direction
6		Protection against heavy seas or powerful water jets (for example, above deck set-up on vessels)
7		Protection against immersion
8		Protection against continuous submersion in water.

Insulation Class

Various insulation materials are used in electric motors and each has its own function:

The most important materials are:

- Wire insulation
- Slot and phase insulation materials (insulation between the winding and the stator lamination pack and phase insulation between the windings heads).
- Winding impregnation.
- Insulating sleeve used to cover wire/lead connections.
- Insulation of winding leads (between the winding and the terminal board).

All these insulation materials are specified in thermal classes that are referenced using a letter (Y–A–E–B–F–H–C). Every thermal class has its own temperature limit specified (see the table). An insulation material of a specific class need to retain its mechanical and electrical properties within the temperature limit and have a reasonably long service life.

The maximum permissible temperature rise (see the table) of the winding is determined based on the thermal class temperature limits. Continuous duty (S1) at the rated power output at an ambient temperature of 40°C is specified for indoor/outdoor installations. The temperature of the winding increases as a result of the copper and iron losses in the electric motor during operation. The winding temperature rise is determined through measuring the resistance of the winding (winding resistance increases with increasing temperature). Hot spots in windings cannot be determined using the winding resistance method. To allow for any Hot Spots in winding lower temperature limits are specified for the used insulation materials.

It is now a common practise to produce motors with insulation class F with winding temperature rise in accordance with the class B (max. 80 K). This means that the motors have a temperature reserve of 25 K. This reserve can be utilised for short-term overload, a higher ambient temperature (above 40°C), for supply voltage/frequency fluctuation etc. Should you know that the thermal reserve would be utilised it is advisable to discuss the application requirements with the motor manufacturer.

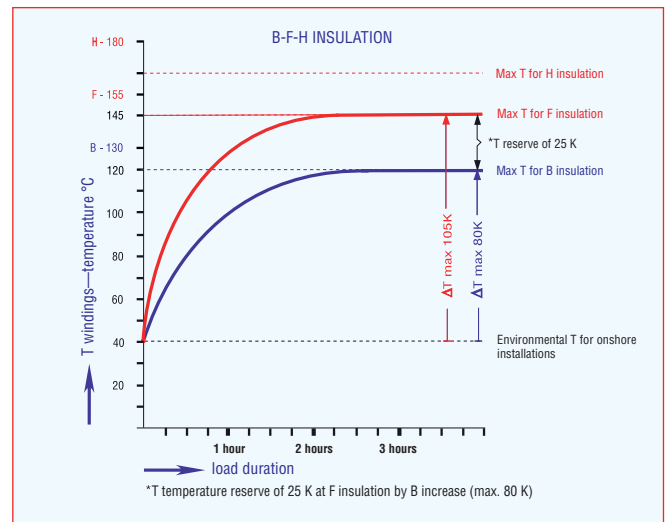

Remark:

The allowable shaft load also decreases when the set-up height increases. The table below provides an overview of this.

Height (m)	1,000	1,500	2,000	2,500	3,000	3,500	4,000
Power (%) T_{max} 40 °C	100	98	95	91	87	83	78

Insulation class	A	E	B	F	H	F*
Temperature limit	105°C	120°C	130°C	155	180	155
Max. temperature of the winding	100°C	115°C	120°C	145°C	165°C	145°C
Environmental temperature for offshore installations	40°C	40°C	40°C	40°C	40°C	40°C
Maximum T (K) of the stator winding	60 K	75 K	80 K	105 K	125 K	80 K + 25 K
Additional thermal reserve						

Insulation class F (155°C) with a winding temperature increase in correspondence with class B (max. 80 K). This creates an additional thermal reserve of 25 K.

Motor Thermal Protection

All electric motors should be protected against overloading. Electric motors will develop a fault when overloaded as the temperature rises above the thermal limit of the insulation materials during the overload, which results in the loss of the mechanical and electrical properties.

Service life

The standard service life of the motor insulation material is 20,000 to 25,000 hours depending on the maximum limit temperature of the individual material. In real life this theoretical service life is exceeded many times. The insulation class B determines the maximum permissible winding temperature of 120°C (limit temperature 130°C) and class F determines the maximum permissible winding temperature of 145°C (limit temperature 155°C). The service life of the winding insulation is reduced by half every time the winding temperature exceeds the maximum permissible temperature by 10 K. Rotor ni® electric motors have been wound in class F (155°C) as standard but the motors' temperature rise is within the class B, well below the class F thermal limit. The service life is therefore expected to exceed the standard service life many times.

Motor protection switch

The temperature of the winding is determined by the energy losses in the electric motor as well as other factors. The "copper losses" are the main contributor to the heat generation. The copper losses are in proportion to the square of the current ($P_{cu} = I^2 \times R$). It is often the case that the temperature does not rise immediately when a specific electric current starts to pass through the winding. The temperature will rise gradually. In order to prevent the damage of the motor winding a current Protection Switch is sometimes used. The electric motor current passes through bi-metal in the switch, which gets warmer. Each metal has a different dilatation property, which results in opening of the circuit when hot. In this case the electric motor does not need to be protected by fuses as they cannot be precisely adjusted for the electric motor current. Unlike bi-metal Protection Switches the fuses do not heat up or cool down with the electric motor winding. It is recommended to set the fuses for a slightly higher current value to prevent tripping of one phase and running on 2 phases. In this case the thermal Protection Switch would trip off too late or not at all. The fuses should only serve as protection against short-circuits.

Protection tool for your driven equipment

The thermal electric motor Protection Switch can also be used as a protection for the driven equipment. The current limit can be set lower than the electric motor rated current. The Protection Switch will trip the motor off even when the motor rated current has not been exceeded. It is not unusual that electric motors run at 30% to 80% of the rated load. It is therefore advisable to adjust the thermal Protection Switch based on the driven equipment requirements.

PT100s

PT100 is a commonly used sensor for temperature measurement. It is a resistance thermometer. Another name is the RTD (Resistance Temperature Detector). Although this expression also includes other types of temperature sensors 70% of all temperature measurements in electric motors are carried out by PT100s. The advantages are wide measurement range, the (almost) linear characteristics, long service life, its accuracy and ease of use and connectivity. The linear relation between temperature and resistance values is a significant difference when compared with PTCs and their characteristics.

The acronym PT refers to platinum being the material from which the very fine resistance wires in PT100s are produced. The number 100 refers to the electrical resistance of 100 Ohm (± 0.1 Ohm) that the sensors have at 0°C.

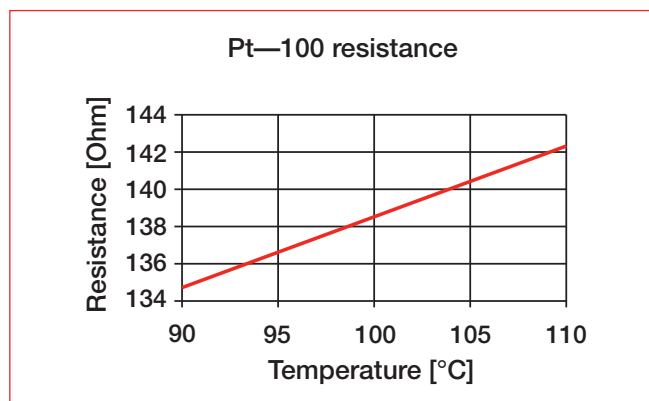
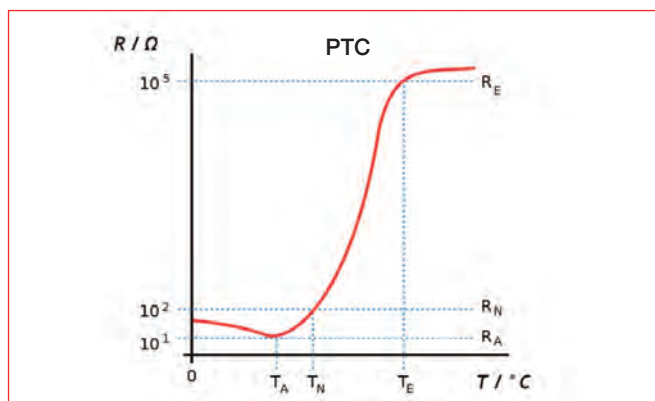

Difference in resistance between a PTC (left) and a PT—100 (right)

PTC thermistors

PTCs are used to protect the motor winding and trip when the maximum permissible winding temperature is reached. The PTC (Positive Temperature Coefficient) is a resistance sensor that has a small resistance value when cold and high resistance value when hot. The PTC has a thermistor effect. This means that the temperature characteristics on the resistance is not linear. The special resistance/temperature curve (can be seen on page 30. PTCs are used in combination with a PTC

thermistor relay in the auxiliary current circuit of the electric motor. The electric motor will be switched off when the limit temperature is reached. This method is independent of the motor current and responds only to the temperature of the winding.

60	70	80	90	100	105	110	115	120	125
130	135	140	145	150	155	160	165	170	180

Colour code of temperature value of PTCs

Anti-condensation (Standstill) heaters

Electric motors that are not continuously running (S1 duty) are usually provided with a standstill or anti-condensation heaters coils (SHC). The heaters switch on when the electric motors are not running and ensure that a constant temperature inside the motor housing is maintained preventing water condensation during sudden differences in temperature inside the electric motors. Water condensation is harmful and can shorten the service life of electric motors. The heaters keep constant temperature in motors after they have been switched off and prevent forming condensation.

Anti-condensation heaters power

Construction size	Watt	Voltage
63	16 W	230 V
71	16 W	230 V
80	16 W	230 V
90	25 W	230 V—(110 V optional)
100	25 W	230 V—(110 V optional)
112	25 W	230 V—(110 V optional)
132	25 W	230 V—(110 V optional)
160	50 W	230 V—(110 V optional)
180	50 W	230 V—(110 V optional)
200	50 W	230 V—(110 V optional)
225	80 W	230 V—(110 V optional)
250	80 W	230 V—(110 V optional)
280	100 W	230 V—(110 V optional)
315	100 W	230 V—(110 V optional)
355	200 W	230 V—(110 V optional)
400	200 W	230 V—(110 V optional)
450	200 W	230 V—(110 V optional)

Motor Cooling

Totally Enclosed Fan Cooled electric motors (TEFC) are air cooled motors provided with an external fan that is fitted on the electric motor's own shaft. Totally Enclosed Force Ventilated motors (TEFV) are equipped with an independently driven fan. In some cases motors are installed in an air flow and are without a fan. These are Totally Enclosed Air Over motors (TEAO). The air necessary for cooling of the motor is usually provided by the driven equipment. The Totally Enclosed Non Ventilated electric motors (TENV) have no fan nor they are subject of forced cooling. Some TENV motors are used for short term duty cycle (i.e. S2-10min duty).

Electric motors with forced cooling (TEFC and TEAO) require approximately 25 to 30 cubic metres of cooling air per minute for 100 kW.

The following are the important features for effective electric motor cooling (this list is not exhaustive):

- **Blade shape**
- **The drive mode**
- **Noise generation**
- **Energy consumption**
- **Electric motor installation and maintenance.**

Blade shape

The simplest option is having the fan mounted directly on to the electric motor shaft. The rotating speed of the electric motor determines the speed of the fan. The required direction of rotation is usually not specified so the standard industrial electric motors are equipped with bi-directional fan with straight blades (radial fan) suitable for both directions of rotation (CW or CCW).

The drive mode

The fan can be directly driven by the electric motor (fitted on motor's own shaft). This is usually used for continuous use (S1 duty).

If an electric motor is frequently switched on and off (for example at S4 duty), additional heat will be generated by the motor especially when there is a large moment of inertia attached to the motor's shaft resulting in heavy start-up. Totally Enclosed Force Ventilated motors (TEFV) are equipped with an independently driven fan, delivering cooling air necessary to cool the motor even when the motor is stationary. This cooling method is often used when motors' speed is controlled by frequency inverters when the motors' own fan becomes ineffective at low speeds.

The force ventilation is suitable for a broad range of voltages. This runs from 230V 50Hz to 575V 60Hz, 3 phase; as indicated on force ventilation unit nameplate. An additional advantage when using this unit is its high protection class: IP66.

Note: If an electric motor runs at a half of the rated speed, the own fan borne by the motor's shaft will deliver only 12.5% of the volume of the cooling air when compared with the air delivery at the motor's rated speed.

Noise generation and energy consumption

The sound pressure level as well as energy consumption can be reduced by using uni-directional axial fans instead of radial fans. The reduction depends on the power and speed. The reduction effect at 6- and 8-pole electric motors (1,000 rpm and 750 rpm) is less significant.

Set-up and maintenance

When installing an electric motor it is important to ensure that the motor will have sufficient supply of cooling air. It is necessary to ensure that the air supply is not blocked in any way and in a dusty environment regular maintenance must be performed and motor cooling ribs cleaned in regular intervals!

Definition of terms

- Direction of rotation **CW** = Clockwise (to the right when viewed from the drive end)
- Direction of rotation **CCW** = Counter Clockwise (to the left when viewed from the drive end)
- **TEFC** = Totally Enclosed Fan Cooled / IC 411
- **TEAO** = Totally Enclosed Air Over / IC 418
- **TENV** = Totally Enclosed Non Ventilated / IC 410
- **TEFV** = Totally Enclosed Force Ventilated / IC 416

IC410

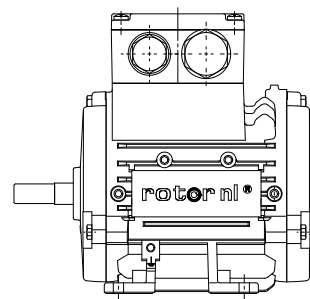

IC411

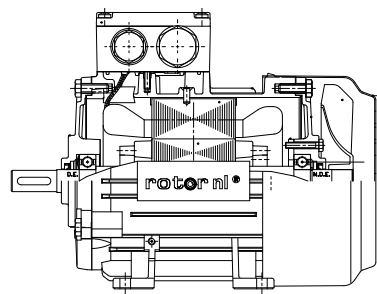

IC416

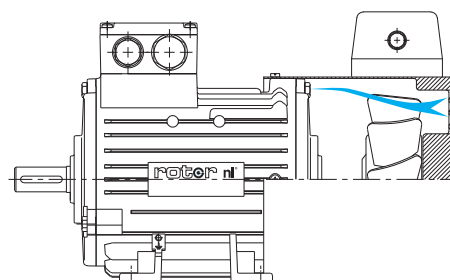

IC416 - force ventilation units - data

Construction size	Δ	Y	A max Δ	A max Y
63	220-290 V	380-500 V	0.1	0.06
71	220-290 V	380-500 V	0.1	0.06
80	220-290 V	380-500 V	0.1	0.06
90	220-290 V	380-500 V	0.33	0.19
100	220-290 V	380-500 V	0.31	0.17
112	220-290 V	380-500 V	0.31	0.17
132	220-290 V	380-500 V	0.45	0.25
160	220-290 V	380-500 V	0.91	0.54
180	220-290 V	380-500 V	0.91	0.54
200	220-290 V	380-500 V	0.91	0.54
225	220-290 V	380-500 V	0.45	0.25
250	220-290 V	380-500 V	0.45	0.25
280	220-290 V	380-500 V	0.91	0.54
315	220-400 V	380-500 V	1.62	0.56
355	230 V	400 V	5.9	3.4
400	230 V	400 V	11	6.4
450	400 V	690 V	8.2	2.9

Sound Pressure Level

Noise level criteria must also be met when installing electric motors depending on the environment and directives applicable on the specific industrial installations with respect to the maximum permissible sound pressure levels. The values included in the table are figures for guidance applicable for standard rotor nI[®] electric motors.

IEC/DIN housing size	Motor speed				Factor Ls
	3.000 min ⁻¹	1.500 min ⁻¹	1.000 min ⁻¹	750 min ⁻¹	
63	53	44	43	-	+ 8.9
71	55	44	43	46	+ 8.9
80	60	47	47	50	+ 9.1
90	64	48	56	54	+ 9.2
100	64	53	52	47	+ 9.4
112	64	55	47	49	+ 9.5
132	66	57	49	49	+ 10.2
160	71	60	50	51	+ 10.2
180	72	62	59	54	+ 10.5
200	73	65	63	58	+ 10.7
225	73	66	57	56	+ 11.0
250	74	67	58	57	+ 11.1
280	75	68	60	57	+ 11.3
315S	79	71	67	65	+ 11.8
315M	80	71	68	65	+ 11.8
355	77	75	71	67	+ 15
400	79	78	73	69	+ 15
450	81	81	75	71	+ 15

Measurements

The sound pressure levels shown in the table are average test values. The specified values apply at no load, 50 Hz speeds and rated voltage with a tolerance of + 3dB. The tests were carried out in accordance with the provisions of ISO1680 and were measured at a distance of 1 metre. 0.02 mPa (milli Pascal) applies as the reference pressure level. The last column provides the factor (Ls) that must be added to the sound pressure to obtain the acoustic power.

Reduced-noise electric motors

Electric motors can be supplied as a reduced-noise execution. They will be fitted with axial fans that is only suitable for one direction of rotation (CW or CCW). The temperature rise of the low-noise electric motors can sometimes be higher than the temperature rise of standard electric motors as the class F would be fully utilised to achieve the required noise reduction.

Noise table in dB(A) for standard electric motors with a bi-directional fan

Pole-changing Electric Motors

Multi-speed Pole-changing electric motors can run at more than one rotating speed. The standard series of pole-changing electric motors supplied by Rotor come with two rotating speeds. However, electric motors with more than two rotating speeds can also be supplied on request. The rotating speeds are achieved by using multiple windings in the motor stator.

Rotor supply the following rotating speed combinations:

3,000rpm/1,500rpm at 50 Hz

1,500rpm/1,000rpm

1,500rpm/750rpm

There are two winding options available for pole-changing electric motors: Dahlander (tapped) winding and two separate windings.

The Dahlander winding is based on one winding which is tapped and can be switched in two ways. The electric motor can run at two speeds. This Dahlander winding is usually used in smaller stators. For larger motor sizes two separate windings are usually used. The disadvantage of the Dahlander winding is that rotating speed must always be in 1:2 ratio.

Electric motors can be provided with two (or in some cases three) separate windings. The advantage of separate winding is that the poles do not have to be in 1:2 ratio. The electric motor can be designed in such a way that the required speeds and power ratings are specifically tailored for the application. The disadvantage is that a larger frame size need to be often used when compared with Dahlander winding. The description of the connection is on page 36.

Voltage/Frequency Inverter

The rotating speed of an electric motor can be controlled by frequency inverter. This variable rotating speed control provides many advantages such as optimisation of production processes and energy saving. The speed and the power needed to drive the driven equipment can be tailored more accurately when a frequency inverter is utilised.

Frequency inverter driven motors consume less energy than fixed speed motors, driven equipment of which often require a different way of control. Pumps and fans are the best applications examples where energy can be saved. It is often the case that the airflow delivered by a fan is greater than actually needed at certain times and the airflow need to be throttled when a fan is driven by fixed speed motor. If the motor is frequency inverter driven, the airflow can be controlled much more economically by regulating the motor speed.

If an electric motor is connected to a frequency inverter, no restrictions apply when the speed control range is between 30% to 120% of the rated speed (at 50 Hz). This applies for variable speed applications (fans and centrifugal pumps)

If constant torque applications speed control is required it is recommended to use force ventilated motors. The motor's own fan becomes ineffective at low speeds and the motor torque need to be derated to as much as 1/3 of the rated torque, depending on the speed control range (IC411). To prevent derating an independently driven fan (force ventilation) is mounted on the back of the electric motor and delivering the required volume of cooling air even when the motor is running at low speed or is stationary (IC416). The rated torque is then available throughout the speed control range. Very low rpm depend on the inverter used. The power (torque) reduction of the driven equipment must correspond with the characteristic of the frequency inverter and electric motor combination. If in doubts please consult the electric motor manufacturer.

PM winding

The type of insulation that is applied when using a frequency inverter is called a Pulse Modulated winding, or the PM winding. Voltage peaks occur during frequency control, which affect the insulation material of the motor winding in the negative way. The standard rotor nI® electric motors are resistant to voltage peaks up to 1,500 V. The use of the PM winding is advisable for rated voltages higher than 500 V combined with inverter control.

The PM winding can handle voltage peaks up to 2,250 V. The PM winding, however, affects the Power Output/ Motor Frame Size relation as the insulation material is thicker and less copper fits in the stator slots so the motors often must be produced in one size higher frame.

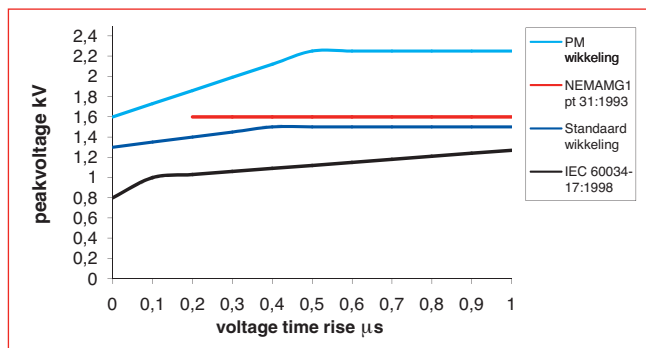

Pulse Generators and Tachometers

Tachometers and encoders (pulse generators) have become even more important since frequency inverters have been introduced to the industry. They act as a feedback for the frequency inverter as they establish the exact position of the motors shaft. The inverter then controls the speed of the motor much more accurately. The accuracy of the process is determined by the number of pulses the encoder can feed back to the inverter.

Tachometer; (analogue)

It can be compared to a dynamo on a bicycle; the harder you pedal, the higher is the voltage and brighter is the light. A tachometer outputs a voltage, which is related to the electric motor speed. The higher is the electric motor speed, the higher is the voltage.

Encoder (pulse generator); (digital)

The encoder emits a number of pulses per revolution (512, 1024, 2048 pulses per rev.). The pulses are used as a feedback to the inverter to control the speed and determine the motor's shaft position. The signal is digital (0 or 1). The principle of the encoder is based on a rotating disc with a number of slots which enable the light to be emitted to an optical recorder. The number of slots are 512, 1024, 2048, etc. The light source (LED) can be found on one side of the disc and the optical recorder can be found on the other side of the disc. The rotating disc interrupts the light emittance so every interruption is an end of the pulse. The more pulses per revolution, the more accurately can the position of the rotor be determined.

Connection Diagrams

Single-speed motors suitable for 2 voltages through a winding connection in Y or Δ

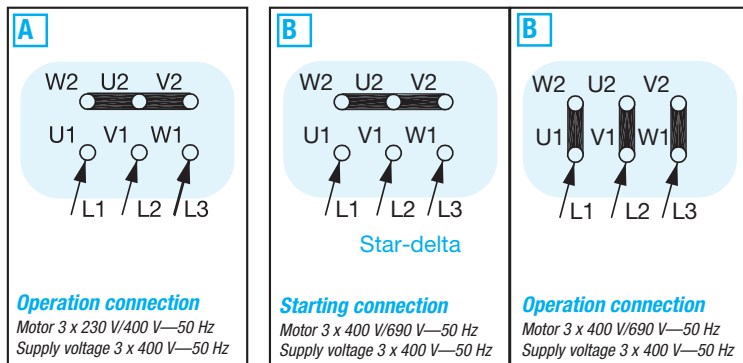

A Motors with a low power (≤ 2.2 kW) are usually actuated directly in the Y state (Direct On Line, DOL). A motor is used for this with a winding that is suitable for $3 \times \Delta 230$ V/Y400 V—50 Hz for a supply voltage of 3×400 V—50 Hz, for example.

B When the power is larger, motors should preferably be connected in the Y state during the initial period in such a way that the winding will then be suitable for $\sqrt{3}$ x the network supply voltage. The motor will, in fact, start to run based on an undervoltage, which means that the starting current will be considerably limited during the initial period. A motor with a winding that is suitable for $3 \times \Delta 400$ V—50 Hz with regard to a supply voltage of 3×400 V—50 Hz, for example, is therefore used.

Pole-changing motors with 2 separate windings

Connection Type	Number of Terminals	Switching-On	
		Low rotational speed	High rotational speed
1 Y/Y	6	Direct	Direct*
2 Δ/Y	9	Star-delta	Direct*
3 Y/Δ	9	Direct	Star-delta
4 Δ/Δ	12	Star-delta	Star-delta

1 Motors with a power that is lower than 2.2 kW with regard to the low rotational speed are usually executed in Y/Y.

2 Motors with more than 2.2 kW in the low rotational speed will be executed in Δ/Y. Motors with type **3** and **4** connections are available (on request) at an additional charge. The low starting current during the entire starting process, even at a high rotational speed, is the advantage of this.

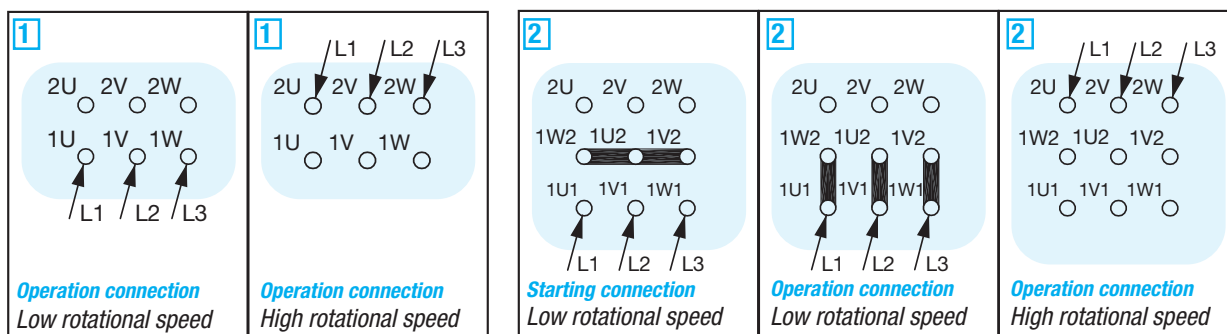

*Remark

It is usual to switch on the high rotational speed through starting in the low rotational speed. The starting current as a result of the direct switching-on in the high rotational speed will, thus, not be limited but the initial period will, however, be shortened by this high current.

Pole-changing motors with Dahlander winding

Connection type	Percentage of low power rotational speed with regard to high	Number of terminals	Switching-On	
			Low rotational speed	High rotational speed
5 Δ/YY	50 to 80 %	6	Direct	Direct*
6 Δ/YY	50 to 80 %	9 (option)	Star-delta	Direct*
7 Y/YY	20 to 30 %	6	Direct	Direct*

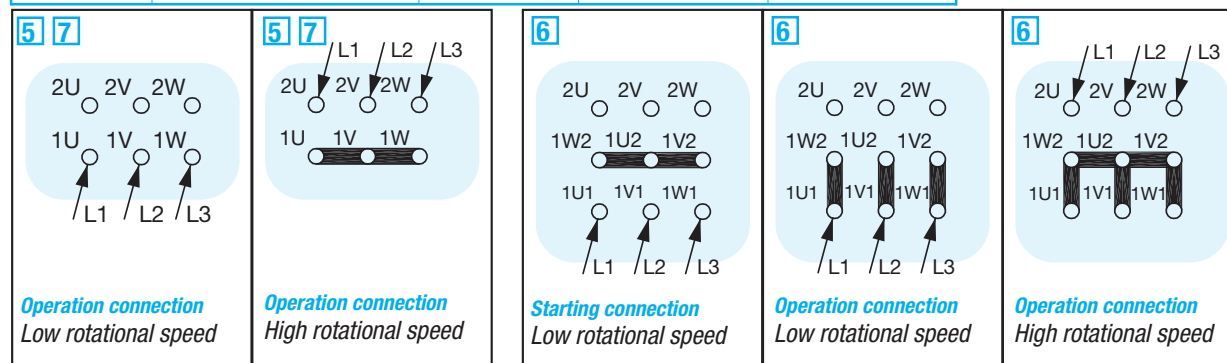

5 **6** Dahlander B connection Δ/YY; delta/double star

The winding will be connected in delta at low rotational speed: with 6 terminals as standard and 9 terminals as an option.

7 Dahlander C connection Y/YY; star/double star

The nominal power at low rotational speed is 20 to 30% of the power at high rotational speed (fan use). The low rotational speed will already be connected internally in star and will be immediately switched on (no switching to delta). The high rotational speed will also be connected in double star for immediate switching-on (no switching to delta).

Introduction

The bearings in an electric motor are used to support the rotor, to bear the forces that are created in the motor and to position the rotor in the stator. The accuracy of the bearing design must meet high criteria to guarantee trouble free electric motor operation. If an electric motor is connected directly to the driven equipment, the bearing of the electric motor often absorb forces

created in by the driven equipment. Rotor n¹® electric motors are equipped with axially pre loaded and located bearings as standard.

Floating bearings

This bearing type is used, for example, for electric motors with sleeve bearings. There is (nearly) no mechanical axial force limitation in the bearings, which means that the shaft has free axial movement. Often the rotor centralises in the stator finding its position through the electromagnetic forces. This position will be ideally determined when the motor is running at no load. A care must be taken when mounting a clutch as no axial forces must be applied on the shaft. Another example of floating bearing design is when the outer rings of both ball bearings slide in the bearing housings and are not axially located.

Located bearings

The outer ring of at least one ball bearing have been fixed in the bearing housing by use of a bearing cap or bearing retainer plate. The located (fixed) bearing cannot move in the axial direction. In comparison with the floating bearing design, the located bearing design prevents the rotor to move axially in relation to the stator. The only possible axial movement under normal circumstances is through the axial play in the ball bearings.

ROTOR STANDARD EXECUTION

Enclosed + located bearings axially preloaded

The outer ring of NDE bearing is "located" in the bearing housing and on the shaft through the shaft circlip. The outer ring can not move axially in relation to the shaft. The located bearing is usually used in combination with an enclosed bearing design and when large axial loads are involved.

Enclosed + located bearings with increased axial pre-loading

Only one ball bearing can be located at a two ball bearing motor design. The other bearing should be able to slide axially in the bearing housing to compensate for any dilatation. Standard wavy washers are used for axial pre-loading or sometimes strengthened wavy washers and/or cup springs are used for increased axial pre-loading.

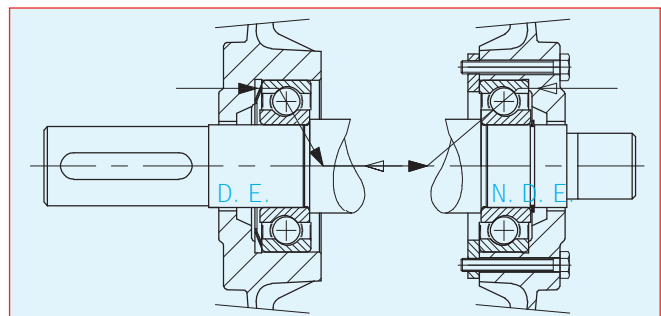
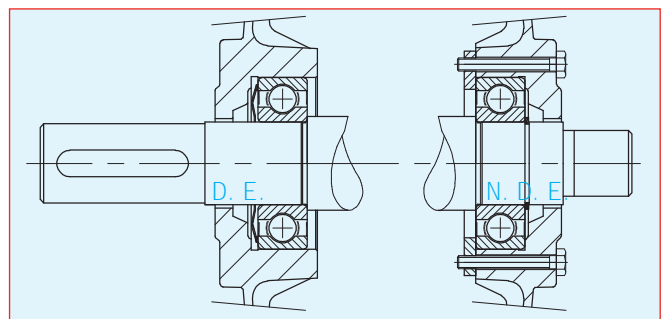
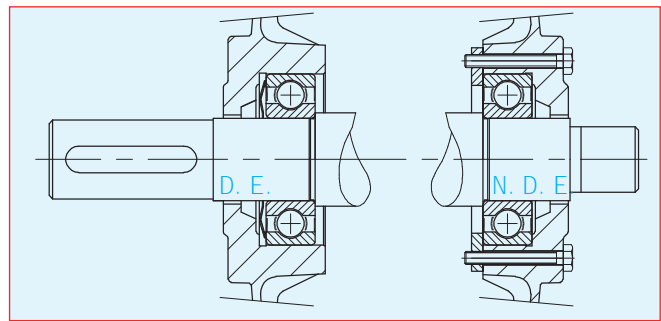
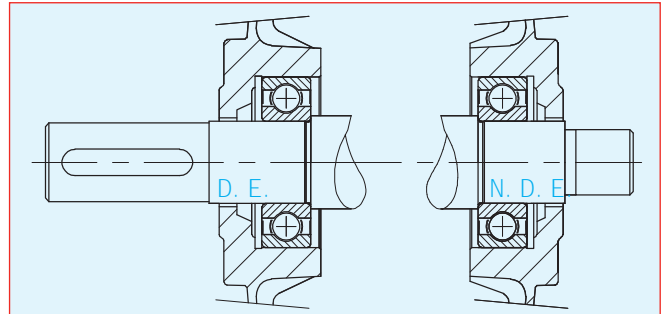

Bearing designs

Bearings are the only components in electric motors that are subject to wear. Standard bearing arrangement is usually sufficient to achieve the required service life where one bearing is located and the other bearing can axially slide in the bearing housing (loose fit). The service life of the bearings can, however, be shortened significantly by excessive load coming from the driven equipment or due to bearing damage resulting from operational conditions. The damage that occurs when pumps or fans are the application and the motors have “floating” bearing arrangement is referred to as “Brinell effect”. The use of “pre-loaded bearings” on both sides can sometimes eliminate the damage. The transferred force is effecting the outer ring of the motor’s bearing where the pump or fan have been mounted and the outer bearing ring of the axially “floating” bearing will start turning inside the bearing housing. This occurs at pumps or fans with a large moment of inertia ($J_{fan} \geq 5 \times J_{rotor}$) or when the fan is unbalanced or as a result of vibrations. The bearing housing will wear out and also frictional corrosion between the outer ring and the bearing housing will occur, which may lead to the jamming of the effected bearing. The rotation of the bearing in the housing will be reduced by applying an axial pre-loading.

Frequent bearing damage occurs when motors are stationary and subject to vibrations. When stationary there is no lubrication film between the balls and the bearing races. The rotor moves as a result of external vibrations. This then leads to impact damage (a Brinell effect) of the balls in the races. The play can be reduced by applying axial pre-loading, which can limit the damage significantly.

Pre-loaded bearing design is a good solution for specific application cases. There are many more bearing designs available so a consultation with the electric motor manufacturer is recommended in order to establish the correct solution for specific applications or operating conditions.

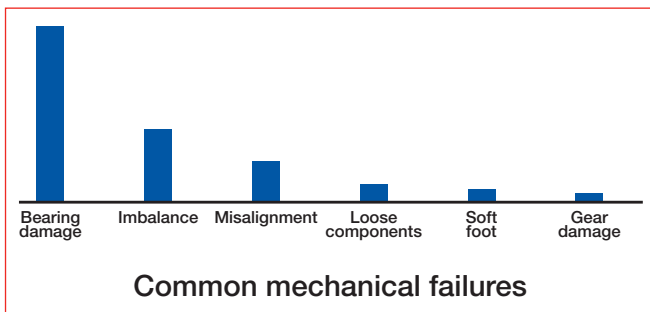

maximum vibrations of electric motors in V eff (mm/sec) and acceleration (m/s ²) in accordance with IEC 60034-14 2003-11 publication							
IEC housing size		56 ≤ H ≤ 132		132 < H ≤ 280		H > 280	
class	mm mounting	V eff mm/s	acceleration m/s ²	V eff mm/s	acceleration mm/s ²	V eff mm/s	acceleration m/s ²
A	free set-up	1.6	2.5	2.2	3.5	2.8	4.4
	fixed set-up	1.3	2	1.8	2.8	2.3	3.6
B	free set-up	0.7	1.1	1.1	1.7	1.8	2.8
	fixed set-up	-	-	0.9	1.4	1.5	2.4

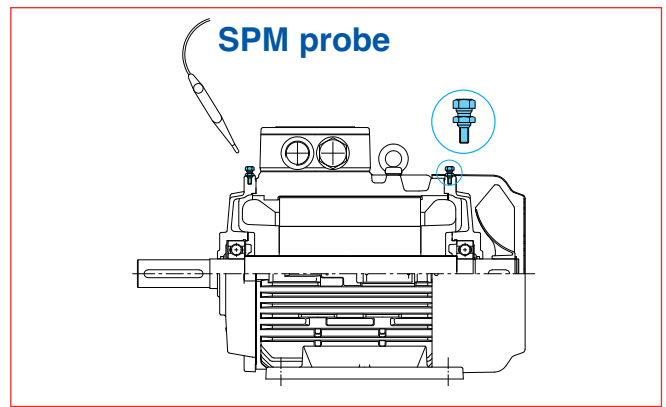

SPM bearing monitoring

Increasing number of customers are starting to use the condition monitoring method. This means that the time of maintenance depends on the condition of the motor and not on the number of working hours.

In order to use this method the suitable testing equipment need to be available to determine the motor condition.

There are a number of different methods used to establish the condition of the bearings whilst in operation. The best known method is the SPM method (Shock Pulse Monitoring method). High-frequency shocks that occur in bearings when rolling elements and races come into contact are translated by a detection system into an instrument monitoring the bearing condition.

The place where an SPM nipple can be positioned is very important for correct measuring result. The fitting of the SPM nipples must also meet specific criteria. We recommend having the SPM nipples or detectors fitted on the new electric motors by qualified professionals to ensure that these criteria are met. **The rotor nI® electric motors can be supplied with SPM measuring nipples or detectors as an option at a surcharge.**

Mechanical Vibrations & Balancing

All rotor nI® electric motors are dynamically balanced with half key in accordance with the IEC 34-14 (2003) standard. The letter H (for Half key) is specified on the rating plate and on the shaft end. The letter F (for Full key) means that balancing has taken place with the full key. It is important that the parts or equipment that are mounted on the motor shaft are balanced accordingly before fitting.

The maximum permissible vibrations of electric motors are defined in the IEC 34-14 standard (see the table). The rotor nI® electric motors meet the vibration class A as standard. It may be a customer requirement to reduce motor vibrations for specific applications. Rotor nI® electric motors can be supplied in the reduced vibration execution of class B (special) upon request.

General

An assumption is usually made when designing electric motors that the motors will be coupled with the driven equipment through a flexible coupling or a V-belt transmission. Electric motors are, however, also often coupled with driven equipments, which transfer axial and/or radial forces originating from the driven equipment onto the motor shaft. Sometimes the load is significantly larger than the axial/radial load of the electric motor. The total axial and/or radial load is then a combination of all forces and the bearing design must always be taken into account when calculating the bearing service life.

The service life of grease-lubricated bearings depends on the following main factors:

- total axial and/or radial load applied on the bearings
- bearing type
- circumferential speed of the bearing (dependant on the electric motor speed)
- temperatures of the bearing and the bearing grease
- quality and lubricating properties of the bearing grease
- operation conditions (i.e. influence of moisture, pollution, external vibrations, etc.)

Ball bearings or cylindrical roller bearings?

Electric motors are by preference provided with ball bearings. Only when the radial load is known to be too high (for the ball bearings) cylindrical roller bearings must (NU bearings) be used on the drive end (DE). These bearings can absorb greater radial forces but the disadvantage is that their re-lubrication intervals are 50% shorter when compared with ball bearings.

A relatively high circumferential speed is involved when large bearings are used in combination with high rotating speeds. This results in grease being mechanically damaged. The service life of the grease also depends on the electric motor mounting. The theoretical service life is halved when the motor is vertically mounted compared to horizontal mounting. External vibrations also have a negative influence on the service life of the grease. "Bleeding" may occur where oil seeps out from the grease.

The bearing temperature is not only determined by the heat development in the bearing with regard to electric motors but also by the added heat from the electric motor or heat that is transferred from the driven equipment. It is important to know that 2-pole electric motors (3,000 rpm) have a rotor higher temperature when compared to multiple-pole electric motors (1,500 and 1,000 rpm). Similarly when electric motors are used for frequency inverter duty the heat losses in the rotor are greater. The heat is then transferred on the shaft and bearings.

Open bearings

An optimum operation temperature of the bearings need to be established when open bearings are used, so the correct amount of grease is applied to guarantee a good lubrication. The grease in bearings loses its lubricating properties as due to mechanical load, ageing and increasing level of contamination. The grease in the open bearings must be replaced on a regular basis. The grease overloading increases the operation temperature of the bearing especially at high rotating speeds. As a general rule the grease filling should be between 30 and 50% of the bearing volume. (An overview is on page 72)

Service life calculation

If the axial and/or radial shaft load (applied on the motor shaft by the driven equipment) when advised to Rotor B.V. can be used for the theoretical bearing service life calculation using the computer software. The calculation can only be used as an indication as the real service life will depend on the factors mentioned above. Rotor nI® electric motors can also be supplied with a special bearing design that has been tailored for a specific application and/or operational conditions (**also see "Maintenance and Operating Instructions"**).

Combination of Frame Size, Dimension and Power

The table below is applicable for self cooled three-phase squirrel-cage electric motors for voltages up to 690V and frequency of 50Hz for continuous (S1) operation of a foot and/or flange mounting. This data are defined in the EN 50 347 standard as well as other standards.

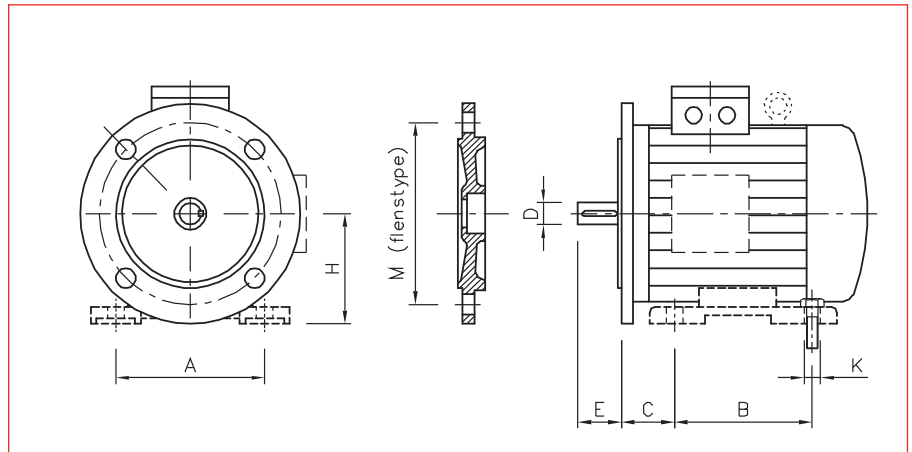

IEC/DIN housing size	Construction sizes in mm				Flange type		Foot holes	Shaft end (D x E) in mm.		Power in kW at 50 Hz at rotational speed:			
	H	B	A	C	FF	FT	K	At rotational speed		3,000 min ⁻¹	1,500 min ⁻¹	1,000 min ⁻¹	750 min ⁻¹
								3,000 min ⁻¹	≤ 1,500 min ⁻¹				
RN63	63	80	100	40	F115	F75	7 (M6)	11 x 23		0.18/0.25	0.12/0.18	-	-
RN71	71	90	112	45	F130	F85	7 (M6)	14 x 30		0.37/0.55	0.25/0.37	-	-
RN80	80	100	125	50	F165	F100	10 (M8)	19 x 40		0.75/1.1	0.55/0.75	0.37/0.55	-
RN90S	90	100	140	56	F165	F115	10 (M8)	24 x 50		1.5	1.1	0.75	0.37
RN90L		125								2.2	1.5	1.1	0.55
RN100L	100	140	160	63	F215	F130	12 (M10)	28 x 60		3	2.2/3	1.5	0.75/1.1
RN112M	112	140	190	70						4	4	2.2	1.5
RN132S	132	140	216	89	F265	F165	12 (M10)	38 x 80		5.5/7.5	5.5	3	2.2
RN132M		178								-	7.5	4/5.5	3
RN160M	160	210	254	108	F300	F215	14.5 (M12)	42 x 110		11/15	11	7.5	4/5.5
RN160L		254								18.5	15	11	7.5
RN180M	180	241	279	121	F300	-	14.5 (M12)	48 x 110		22	18.5	-	-
RN180L		279								-	22	15	11
RN200L	200	305	318	133	F350	-	18.5 (M16)	55 x 110		30/37	30	18.5/22	15
RN225S	225	286	356	149	F400	-	18.5 (M16)	55 x 110	60 x 140	-	37	-	18.5
RN225M		311								45	45	30	22
RN250M	250	349	406	168	F500	-	24 (M20)	60 x 140	65 x 140	55	55	37	30
RN280S	280	368	457	190	F500	-	24 (M20)	65 x 140	75 x 140	75	75	45	37
RN280M		419								90	90	55	45
RN315S	315	406	508	216	F600	-	28 (M24)	65 x 140	80 x 170	110	110	75	55
RN315M		457								132	132	90	75
RN315L	315	508	508	216	F600	-	28 (M24)	65 x 140	80 x 170	160	160	110	90
RN315L-8/9										F740	200	200	132
RNN315L	315	630	560	180	F740	-	26 (M24)	65 x 140	85 x 170	250/315	250/315	200/250	160/200
RNN315L				200*					-				
RNN355L	355	800	630	200	F840	-	33 (M30)	75 x 140	95 x 170	355/400/500	355/400/500	315/400	250/315
RNN355L				224*					-				
RNN400L	400	900	710	224	F940	-	33 (M30)	80 x 170	100 x 210	560/630/710	650/630/710	450/500/560	355/400/450
RNN450	450	1,000	800	250	F1,080	-	39 (M36)	80 x 170	110 x 210	800/900/1,000	800/900/1,000	630/710/800	500/560/630

* NU bearing application.

Flange and Shaft Dimensions

Flange dimensions

IEC/DIN	IM 3001/IM B5				IM 3601/IM B14A				IM 3601/IM B14B			
	M	P(max)	N	S	M	P(max)	N	S	M	P(max)	N	S
RN63	115	140	95j6	10	75	90	60j6	M5	100	120	80j6	M6
RN71	130	160	110j6	10	85	105	70j6	M6	115	140	95j6	M8
RN80	165	200	130j6	12	100	120	80j6	M6	130	160	110j6	M8
RN90					115	140	95j6	M8				
RN100	215	250	180j6	14.5	130	160	110j6	M8	165	200	130j6	M10
RN112												
RN132	265	300	230j6	14.5	165	200	130j6	M10				
RN160	300	350	250j6	18.5								
RN180												
RN200	350	400	300h6	18.5								
RN225	400	450	350h6	18.5								
RN250	500	550	450h6	18.5								
RN280												
RN315	600	660	550h6	24								
RN315-8/9	740	800	680h6	22								
RNN355	840	900	780h6	22								
RNN400	940	1,000	880h6	22								
RNN450	1,080	1,150	1,000h6	26								

By preference, the following information should be provided when ordering flange-mounted electric motors;

1° fixing hole type

FF = free holes

FT = tapped holes

2° M-size (fixing hole pitch)

Examples:

FF265: is IM 3001/B5—flange
 $\varnothing 300 \times \varnothing 265 \times \varnothing 230$ mm.
 with free holes.

FT115: is IM 3601/B14—flange
 $\varnothing 140 \times \varnothing 115 \times \varnothing 95$ mm.
 with M8 tapped holes.

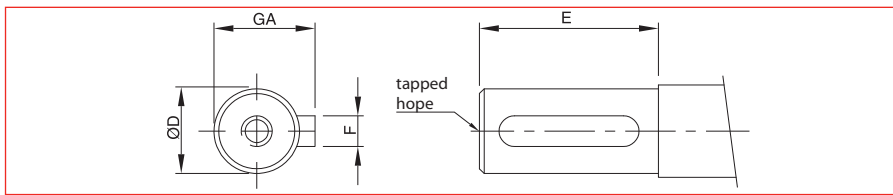
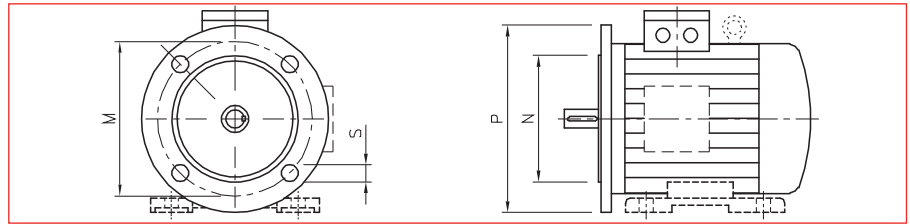

Housing size type	Shaft		Flange FF		Flens FT (B14A)	
	Standard	Optional	Standard	Optional	Standard	Optional
RN63	$\varnothing 11$	$\varnothing 9$	115	-	75	-
RN71	$\varnothing 14$	$\varnothing 11$	130	115	85	75/100
RN80	$\varnothing 19$	$\varnothing 14$	165	130	100	85
RN90	$\varnothing 24$	$\varnothing 19$	165	130	115	100
RN100	$\varnothing 28$	$\varnothing 24$	215	165	130	-
RN112	$\varnothing 28$	$\varnothing 24$	215	-	130	-
RN132	$\varnothing 38$	$\varnothing 28$	265	215	165	130
RN160	$\varnothing 42$	$\varnothing 38$	300	265		215
RN180	$\varnothing 48$	$\varnothing 42$	300	265		
RN200	$\varnothing 55$	$\varnothing 48$	350	300		
RN225-2	$\varnothing 55$	$\varnothing 48$	400	300/350		
RN225-4/6/8	$\varnothing 60$	$\varnothing 55$	400	300/350		
RN250-2	$\varnothing 60$	$\varnothing 55$	500	400		
RN250-4/6/8	$\varnothing 65$	$\varnothing 60$	500	400		
RN280-2	$\varnothing 65$	$\varnothing 60$	500	400		
RN280-4/6/8	$\varnothing 75$	$\varnothing 65$	500	400		
RN315-2	$\varnothing 65$	$\varnothing 60$	600	-		
RN315-4/6/8	$\varnothing 80$	$\varnothing 75$	600	500/740		
RN315-4/6/8-8/9	$\varnothing 85$		740			
RNN315-2	$\varnothing 65$		740			
RNN315-4/6/8	$\varnothing 85$		740			
RNN315-4/6/8*	$\varnothing 95$		740			
RNN355-2	$\varnothing 75$		840			
RNN355-4/6/8	$\varnothing 95$		840			
RNN355-4/6/8*	$\varnothing 100$		840			
RNN355 E27-2/4	$\varnothing 95$		840			
RNN400-2	$\varnothing 80$		940			
RNN400-4/6/8	$\varnothing 110$		940			
RNN450-2	$\varnothing 90$		1,080			
RNN450-4/6/8	$\varnothing 120$		1,080			

* Fitted with NU bearings.

Shaft dimensions

The shaft and flange dimensions specified in the dimensional drawings comply with the provisions of the relevant standard. The key and keyway comply with the NEN EN 50 347 standard. The electric motor shafts are equipped with an internal metric thread as indicated in the table below.

Shaft diameter D	Sizes in mm			
	E	F	GA	Tapped hole
$\varnothing 9j6$	20	3	10.2	M3
$\varnothing 11j6$	23	4	12.5	M4
$\varnothing 14j6$	30	5	16	M5
$\varnothing 19j6$	40	6	21.5	M6
$\varnothing 24j6$	50	8	27	M8
$\varnothing 28j6$	60	8	31	M10
$\varnothing 38k6$	80	10	41	M12
$\varnothing 42k6$	110	12	45	M16
$\varnothing 48k6$	110	14	51.5	M16
$\varnothing 55m6$	110	16	59	M20
$\varnothing 60m6$	140	18	64	M20
$\varnothing 60m6$	140	18	69	M20
$\varnothing 70m6$	140	20	74.5	M20
$\varnothing 75m6$	140	20	79.5	M20
$\varnothing 80m6$	170	22	85	M20
$\varnothing 85m6$	170	22	85	M20
$\varnothing 90m6$	170	25	95	M24
$\varnothing 95m6$	170	25	100	M24
$\varnothing 100m6$	210	28	106	M24
$\varnothing 110m6$	210	28	116	M24
$\varnothing 120m6$	210	32	127	M24

A Regal Brand

REGAL

Dimensional Drawings of RN + RNN series 3-phase Electric Motors

IEC_DIN enclosure size	Type	MOTOR							
		H	A	AB	B	C	AD	HD	K
63	5RN63M	63	100	120	80	40		164	7
71	5RN71M	71	112	132	90	45		182	7
80	5RN80M02K	80	125	150	100	50	120	200	9,5
	5RN80M 2/4	80	125	150	100	50	128	200	9,5
90	5RN90S 2/4/6	90	140	165	100	56	128	218	10
	5RN90L 2/4	90	140	165	125	56	161	218	10
	5RN90L 6	90	140	165	125	56	161	218	10
100	6RN100L	100	160	196	140	63	193	293	12
112	6RN112M	112	190	226	140	70	195	307	12
132	6RN132S	132	216	256	140	89	214,5	347	12
	6RN132M	132	216	256	178	89	214,5	347	12
160	6RN160M	160	254	300	210	108	261	421	15
	6RN160L	160	254	300	254	108	261	421	15
180 M	6RN180M2E22	180	279	339	241	121	286	466	15
	6RN180M4E22	180	279	339	241	121	286	466	15
	6RN180M2E26	180	279	339	241	121	286	466	15
180 L	6RN180L4E24, 6RN180L4E26	180	279	339	279	121	286	466	15
	6RN180L6E24, 6RN180L6E26	180	279	339	279	121	286	466	15
200 L	6RN200L2E24, 6RN200L2E25	200	318	378	305	133	315	515	19
	6RN200L4E25	200	318	378	305	133	315	515	19
	6RN200L6E24, 6RN200L6E25	200	318	378	305	133	315	515	19
	6RN200L2E26	200	318	378	305	133	315	515	19
	6RN200L4E26	200	318	378	305	133	315	515	19
225 S	6RN225S4E20, 6RN225S8E20	225	356	436	286	149	338	563	19
225 M	6RN225M2E22	225	356	436	311	149	338	563	19
	6RN225M4E22, 6RN225M6E22	225	356	436	311	149	338	563	19
	6RN225M8E22	225	356	436	311	149	338	563	19
	6RN225M2E26	225	356	436	311	149	338	563	19
	6RN225M4E26, 6RN225M6E26, 6RN225M8E26	225	356	436	311	149	338	563	19
250 M	6RN250M2E22	250	406	490	349	168	410	660	24
	6RN250M4E22, 6RN250M6E22, 6RN250M8E22	250	406	490	349	168	410	660	24
	6RN250M2E26	250	406	490	349	168	410	660	24
	6RN250M4E26	250	406	490	349	168	410	660	24
	6RN250M6E26, 6RN250M8E26	250	406	490	349	168	410	660	24
280 S	6RN280S2E20	280	457	540	368	190	433	713	24
	6RN280S4E20, 6RN280S6E20, 6RN280S8E20	280	457	540	368	190	433	713	24
280 M	6RN280M2E22	280	457	540	419	190	433	713	24
	6RN280M4E22, 6RN280M6E22, 6RN280M8E22	280	457	540	419	190	433	713	24
	6RN280M2E26	280	457	540	419	190	433	713	24
	6RN280M4E26	280	457	540	419	190	433	713	24
	6RN280M6E26, 6RN280M8E26	280	457	540	419	190	433	713	24
315 S	6RN315S2E20	315	508	610	406	216	515	830	28
	6RN315S4E20, 6RN315S6E20, 6RN315S8E20	315	508	610	406	216	515	830	28
315 M	6RN315M2E22	315	508	610	457	216	515	830	28
	6RN315M4E22	315	508	610	457	216	515	830	28
	6RN315M6E22, 6RN315M8E22	315	508	610	457	216	515	830	28
315 L	6RN315L2E24	315	508	610	508	216	515	830	28
	6RN315L4E24, 6RN315L6E24, 6RN315L8E24	315	508	610	508	216	515	830	28
	6RN315L2E25	315	508	610	508	216	515	830	28
	6RN315L4E25	315	508	610	508	216	515	830	28
	6RN315L6E25, 6RN315L8E25, 6RN315L8E26	315	508	610	508	216	515	830	28
	6RN315L2E26	315	508	610	508	216	515	830	28
	6RN315L4E26, 6RN315L6E26	315	508	610	508	216	515	830	28
315	5RN315L E28 2	315	560	680	630	180	570	783	26
	5RN315L E28 4/6/8	315	560	680	630	180	570	783	26
	5RNN315L E28 4/6/8 (*)	315	560	680	630	200	570	783	26
355	5RNN355L 2	355	630	780	800	200	690	895	33
	5RNN355L 4/6/8	355	630	780	800	200	690	895	33
	5RNN355L E27 2/4	355	630	780	800	200	829	945	33
	5RNN355L E28 4/6/8 (*)	355	630	780	800	224	690	945	33
400	5RNN400L 2	400	710	860	900	224	865	1025	33
	5RNN400L 4/6/8	400	710	860	900	224	865	1025	33
450	5RNN450L 2 (**)	450	800	980	1000	250	900	1110	39
	5RNN450L 4/6/8	450	800	980	1000	250	900	1110	39

* = Voorzien van Nu Lagers. Geen tweede aseind mogelijk
 ** = Only 50 Hz

Increased output

IEC_DIN enclosure size	Type	MOTOR							
		H	A	AB	B	C	AD	HD	K
63-V		63	100	120	80	40		164	7
71-V		71	112	132	90	45		182	7
80-V		80	125	150	100	50	128	200	9,5
90-V		90	140	165	125	56	161	218	10
100-V		100	160	196	140	63	193	293	12
112-V		112	190	226	140	70	195	307	12
132-V		132	216	256	178	89	214,5	347	12
160-V		160	254	300	254	108	261	421	15
315L-V	2	315	508	610	508	216	500	815	28
	4 E28	315	508	610	508	216	500	815	28
	6/8 E28	315	508	610	508	216	500	815	28
	2 E29	315	508	610	508	216	500	815	28
	4/6 E29	315	508	610	508	216	500	815	28
	8 E29	315	508	610	508	216	500	815	28

SHAFT						
L	W	Z	D	E	F	GA
202,5	M16 / M25	>50	11	23	4	12,5
240	M16 / M25	>50	14	30	5	16
273,5	M16 / M25	>50	19	40	6	21,5
308,5	M16 / M25	>50	19	40	6	21,5
331	M16 / M25	>50	24	50	8	27
358	M16 / M25	>50	24	50	8	27
376	M16 / M25	>50	24	50	8	27
402	M32	>50	28	60	8	31
385	M32	>50	28	60	8	31
456,5	M32	>50	38	80	10	41
456,5	M32	>50	38	80	10	41
596	M40	>60	42	110	12	45
596	M40	>60	42	110	12	45
668	M40	>65	48	110	14	51,5
668	M40	>65	48	110	14	51,5
698	M40	>65	48	110	14	51,5
698	M40	>65	48	110	14	51,5
668	M40	>65	48	110	14	51,5
721	M50	>70	55	110	16	59
721	M50	>70	55	110	16	59
746	M50	>70	55	110	16	59
746	M50	>70	55	110	16	59
788	M50	>70	60	140	18	64
818	M50	>70	55	110	16	59
848	M50	>70	60	140	18	64
788	M50	>70	60	140	18	64
818	M50	>70	55	110	16	59
848	M50	>70	60	140	18	64
887	M63	>75	60	140	18	64
887	M63	>75	65	140	18	69
887	M63	>75	60	140	18	64
957	M63	>75	65	140	18	69
887	M63	>75	65	140	18	69
960	M63	>75	65	140	18	69
960	M63	>75	75	140	20	79,5
960	M63	>75	65	140	18	69
960	M63	>75	75	140	20	79,5
1070	M63	>75	65	140	18	69
1070	M63	>75	75	140	20	79,5
960	M63	>75	75	140	20	79,5
1052	M63	>100	65	140	18	69
1082	M63	>100	80	170	22	85
1217	M63	>100	65	140	18	69
1247	M63	>100	80	170	22	85
1082	M63	>100	80	170	22	85
1217	M63	>100	65	140	18	69
1247	M63	>100	80	170	22	85
1372	M63	>100	65	140	18	69
1402	M63	>100	80	170	22	85
1247	M63	>100	80	170	22	85
1372	M63	>100	65	140	18	69
1402	M63	>100	80	170	22	85
1372	M72/M20	>100	65	140	18	69
1410	M72/M20	>100	85	170	22	90
1430	M72/M20	>100	95	170	25	100
1605	M80/M25	>120	75	140	20	79,5
1635	M80/M25	>120	95	170	25	100
1635	M80/M25	>120	95	170	25	100
1699	M80/M25	>120	100	210	28	106
1793	M80/M25	>150	80	170	22	85
1833	M80/M25	>150	110	210	28	116
1953	M80/M25	>150	90	170	25	95
1993	M80/M25	>150	120	210	32	127

SHAFT						
L	W	Z	D	E	F	GA
228,5	M16 / M25	>50	11	23	4	12,5
240	M16 / M25	>50	14	30	5	16
308,5	M16 / M25	>50	19	40	6	21,5
331	M16 / M25	>50	24	50	8	27
415	M32	>50	28	60	8	31
415,5	M32	>50	28	60	8	31
516,5	M32	>50	38	80	10	41
660	M40	>60	42	110	12	45
1442	M63	>100	65	140	18	69
1402	M63	>100	85	170	22	85
1402	M63	>100	85	170	22	85
1372	M72	>100	65	140	18	69
1546	M72	>100	80	170	22	85
1426	M72	>100	85	170	22	90

Electric motor for foot mounting

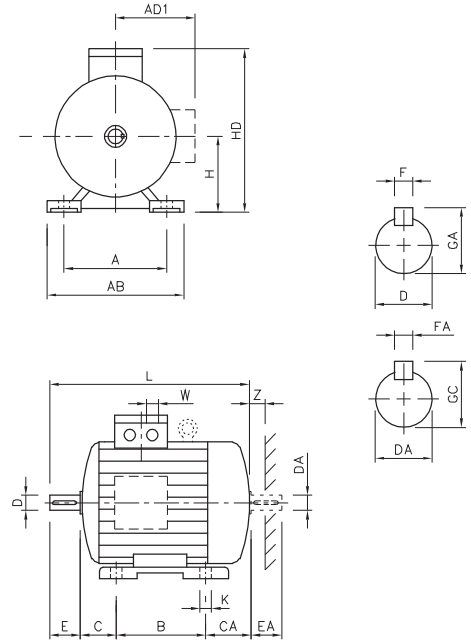

Electric motor for (foot)/flange mounting

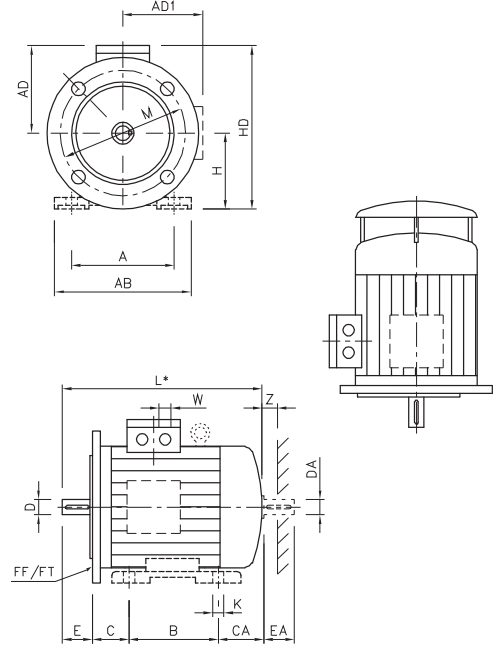

Dimensional Drawings of RN-IE3 series 3-phase Electric Motors

IEC_DIN enclosure size	Type	MOTOR							
		H	A	AB	B	C	AD	HD	K
180 M	6RN180M4E32	180	279	339	241	121	286	466	15
	6RN180M2E32	180	279	339	241	121	286	466	15
180 L	6RN180L4E34	180	279	339	279	121	286	466	15
	6RN180L6E34	180	279	339	279	121	286	466	15
200 L	6RN200L2E34	200	318	378	305	133	315	515	19
	6RN200L2E35	200	318	378	305	133	315	515	19
	6RN200L4E35, 6RN200L6E35	200	318	378	305	133	315	515	19
	6RN200L6E34	200	318	378	305	133	315	515	19
	6RN200L6E35	200	318	378	305	133	315	515	19
225 S	6RN225S4E30	225	356	436	286	149	338	563	19
225 M	6RN225M2E32	225	356	436	311	149	338	563	19
	6RN225M4E32, 6RN225M6E32	225	356	436	311	149	338	563	19
250 M	6RN250M2E32	250	406	490	349	168	410	660	24
	6RN250M4E32, 6RN250M6E32	250	406	490	349	168	410	660	24
280 S	6RN280S2E30	280	457	540	368	190	433	713	24
	6RN280S4E30, 6RN280S6E30	280	457	540	368	190	433	713	24
280 M	6RN280M2E32	280	457	540	419	190	433	713	24
	6RN280M4E32	280	457	540	419	190	433	713	24
	6RN280M6E32	280	457	540	419	190	433	713	24
	6RN280M6E32	280	457	540	419	190	433	713	24
315 S	6RN315S2E30	315	508	610	406	216	515	830	28
	6RN315S4E30, 6RN315S6E30	315	508	610	406	216	515	830	28
315 M	6RN315M2E32	315	508	610	457	216	515	830	28
	6RN315M4E32, 6RN315M6E32	315	508	610	457	216	515	830	28
315 L	6RN315L2E34	315	508	610	508	216	515	830	28
	6RN315L4E34, 6RN315L6E34	315	508	610	508	216	515	830	28
	6RN315L2E35	315	508	610	508	216	515	830	28
	6RN315L4E35, 6RN315L6E35	315	508	610	508	216	515	830	28
	6RN315L6E36	315	508	610	508	216	515	830	28

SHAFT						
L	W	Z	D	E	F	GA
668	M40	>65	48	110	14	51,5
698	M40	>65	48	110	14	51,5
698	M40	>65	48	110	14	51,5
668	M40	>65	48	110	14	51,5
721	M50	>70	55	110	16	59
746	M50	>70	55	110	16	59
746	M50	>70	55	110	16	59
721	M50	>70	55	110	16	59
788	M50	>70	60	140	18	64
818	M50	>70	55	110	16	59
848	M50	>70	60	140	18	64
887	M63	>75	60	140	18	64
887	M63	>75	65	140	18	69
960	M63	>100	65	140	18	69
960	M63	>100	75	140	20	79,5
1070	M63	>100	65	140	18	69
1070	M63	>100	75	140	20	79,5
960	M63	>100	75	140	20	79,5
1052	M63	>100	65	140	18	69
1082	M63	>100	80	170	22	85
1217	M63	>100	65	140	18	69
1247	M63	>100	80	170	22	85
1217	M63	>100	65	140	18	69
1247	M63	>100	80	170	22	85
1372	M63	>100	65	140	18	69
1402	M63	>100	80	170	22	85
1402	M63	>100	80	170	22	85

Single-phase Electric Motors Dimensions

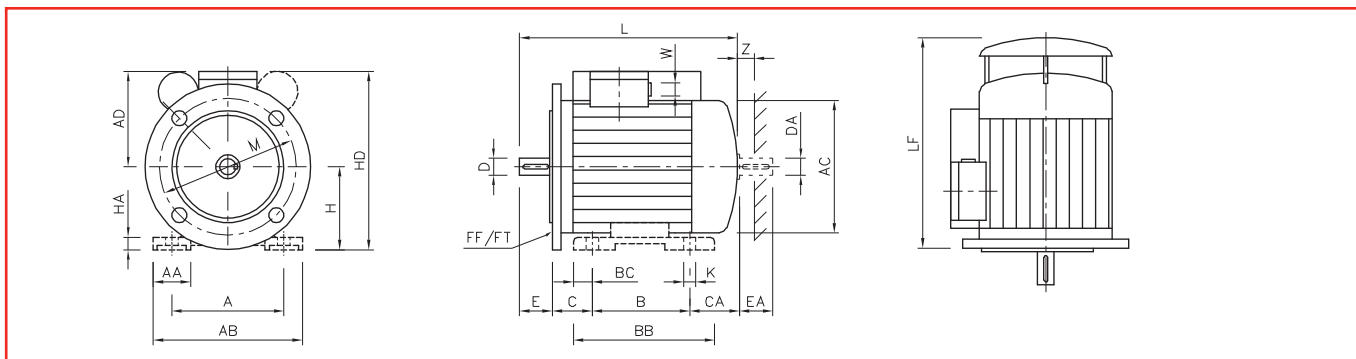
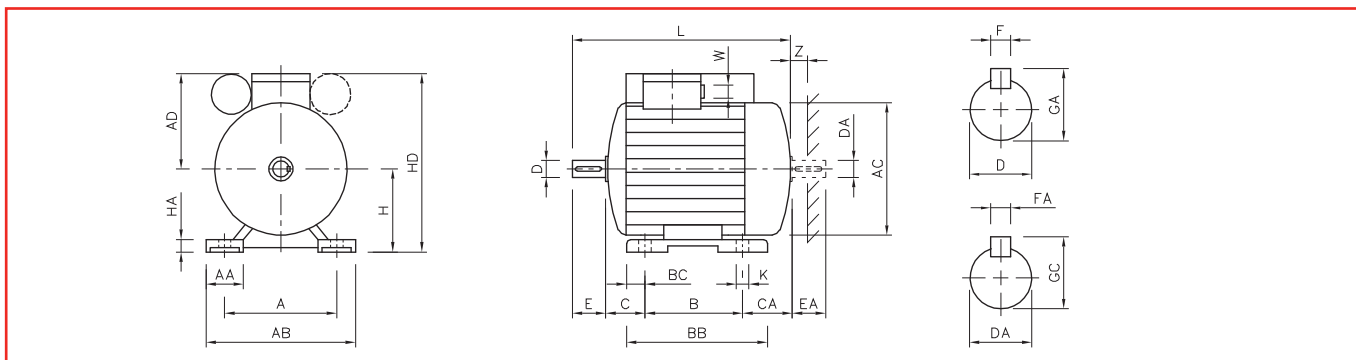

IEC_DIN Housing size	Standard motors for foot and/or flange mount											Sizes in mm			
	H	A	AB	AC	AD1	B	BB	C	CA	HD	K'	L	LF	L*	LF*
63,,K	63	100	120	118	-	80	96	40	56	164	7 (M6)	203	209	254	209
63	63	100	120	118	-	80	96	40	56	164	7 (M6)	229	209	280	209
71,,K	71	112	132	139	-	90	106	45	83	182	7 (M6)	240	238	291.5	238
71	71	112	132	139	-	90	106	45	83	182	7 (M6)	240	238	291.5	238
80,,K	80	125	150	156	120	100	118	50	94	200	10 (M8)	274	263	328	263
80,,2.6	80	125	150	156	120	100	118	50	94	200	10 (M8)	316.5	263	328	263
80,,4	80	125	150	156	120	100	118	50	94	200	10 (M8)	274	263	328	263
90S	90	140	165	174	128	100	143	56	143	218	10 (M8)	331	333	382.5	333
90L-2,6	90	140	165	174	128	125	143	56	118	218	10 (M8)	374	333	382.5	333
90L-4	90	140	165	174	128	125	143	56	118	218	10 (M8)	331	333	413.5	333
100L	100	160	192	195	161	140	180	63	125	261	12 (M10)	426	365	459	365

IEC_DIN Housing size	Standard motors for foot and/or flange mount											Sizes in mm		
	W	Z	D	E	F	GA	DA	EA	FA	GC	Flanges (M-SIZES)			
63,,K	M16 + M25	> 50	11j6	23	4	12.5	11j6	23	4	12.5	FF 115	FT 75	FT 100	
63	M16 + M25	> 50	11j6	23	4	12.5	11j6	23	4	12.5	FF 115	FT 75	FT 100	
71,,K	M16 + M25	> 50	14j6	30	5	16	14j6	30	5	16	FF 130	FT 85	FT 115	
71	M16 + M25	> 50	14j6	30	5	16	14j6	30	5	16	FF 130	FT 85	FT 115	
80,,K	M16 + M25	> 50	19j6	40	6	21.5	19j6	40	6	21.5	FF 165	FT 100	FT 130	
80,,2.6	M16 + M25	> 50	19j6	40	6	21.5	19j6	40	6	21.5	FF 165	FT 100	FT 130	
80,,4	M16 + M25	> 50	19j6	40	6	21.5	19j6	40	6	21.5	FF 165	FT 100	FT 130	
90S	M16 + M25	> 50	24j6	50	8	27	24j6	50	8	27	FF 165	FT 115	FT 130	
90L-2,6	M16 + M25	> 50	24j6	50	8	27	24j6	50	8	27	FF 165	FT 115	FT 130	
90L-4	M16 + M25	> 50	24j6	50	8	27	24j6	50	8	27	FF 165	FT 115	FT 130	
100L	M16 + M25	> 50	28j6	60	8	31	28j6	60	8	31	FF 215	FT 130	FT 165	

- Standardised in accordance with EN 50347, IEC72-1 and DIN 42925
- Non-standardised sizes (depending on the type and model)
- Standardised sizes but not binding for the IEC-DIN housing size

L and LF sizes RC
 L* and LF* sizes RCC
 CA and DA are only possible with the motor RC

Section 4

Rotor Product Range

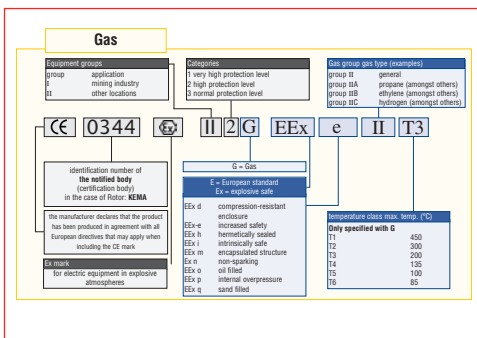
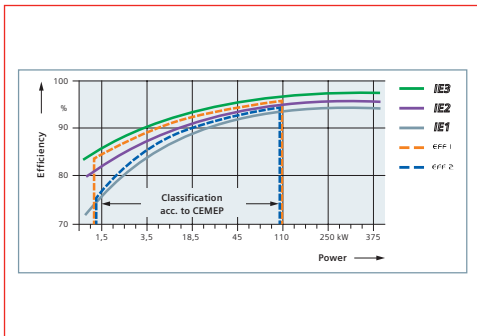

46	RN Series 3-phase Motor Electric Data
48	Standard line 3-phase Electric Motors with Increased Power/Extended Stator Pack
49	Single-phase Electric Motors RCC and RC
50	Marine Applications
51	Offshore Applications
52	Marine & Offshore
52	Shipping Classification Bureaus
55	Explosive atmosphere
55	Category and area classification
55	Coding for Electric Motors in Gas Explosive Atmospheres
56	ATEX Ex-d(e) Flame Proof Electric Motors
58	ATEX Ex-e Increased Safety Electric Motors
59	ATEX Ex-nA Non-Sparking Electric Motors
62	Category and Area Classification for Dusty Atmospheres (dust)
62	Coding for Electric Motors in Dust Explosive Area
63	Motor Execution Options
64	Pole-changing Motors Electrical Data
68	Brake Motors and Backstop

In the following pages you will find information about the standard range of rotor nI® electric motors and the details and modification options for an ATEX motor.

RN Series 3-phase Motor Electric Data

IEC housing size	Complies with	Power	Speed	Nominal current	Nominal current	Power Factor	Efficiency	Efficiency	Starting current	Starting torque	Stall torque	Nominal torque	Mass inertia J	Mass
Type		kW	min ⁻¹	at 400 V	at 690 V	cos φ	4/4 load %	3/4 load %	Ia/In	Ma/Mn	Mk/Mn	Nm	kgm ²	kg
<i>2 polig synchron loerental 3000 min⁻¹</i>														
RN63M02K	-	0,18	2840	0,48	-	0,78	70		4,8	2,8	3,1	0,61	0,00022	4,1
RN63M02	-	0,25	2840	0,63	-	0,8	72		4,9	2,5	2,5	0,84	0,00026	5,1
RN71M02K	-	0,37	2840	0,94	-	0,77	74		6,5	3,3	3,1	1,2	0,00041	6
RN71M02	-	0,55	2835	1,42	-	0,75	75		6,3	3,6	2,9	1,9	0,0005	7,2
RN80M02E2K	IE2	0,75	2870	1,71	-	0,82	77,4	77,4	8,3	4,4	3,2	2,5	0,001	9,8
RN80M02E2	IE2	1,1	2860	2,25	-	0,89	79,6	79,6	7	3,8	3,2	3,7	0,0013	12,3
RN90S02E2	IE2	1,5	2890	3,05	-	0,87	81,3	81,3	7	4,1	3,5	5	0,0018	15
RN90L02E2	IE2	2,2	2890	4,4	-	0,87	83,2	83,2	7	4,1	3,5	7,3	0,0022	18,6
RN100L02E2	IE2	3	2905	6,1	3,52	0,84	84,6	85	7	2,3	3,3	9,9	0,0044	21
RN112M02E2	IE2	4	2950	7,8	4,50	0,86	85,8	86	7,4	2,4	3,3	13	0,0092	27
RN132S02E2K	IE2	5,5	2950	10,4	6,00	0,87	87	87,5	6,7	1,8	2,9	18	0,02012	39
RN132S02E2	IE2	7,5	2950	14,2	8,20	0,87	88,1	88,6	7,5	2,2	3,1	24	0,02353	43
RN160M02E2K	IE2	11	2955	20,5	11,8	0,87	89,4	89,5	7,4	2,1	3,2	36	0,04471	67
RN160M02E2	IE2	15	2955	27	15,6	0,88	90,3	90,3	7,6	2,4	3,4	48	0,05277	75
RN160L02E2	IE2	18,5	2955	33,5	19,3	0,88	90,9	91,2	7,9	2,9	3,6	60	0,06085	84
6RN180M02E22	IE2	22	2940	40	23	0,87	91,3	91,8	7,4	2,7	3,6	71	0,069	145
6RN200L02E24	IE2	30	2960	54	31	0,87	92,0	92,3	6,9	2,5	3,3	97	0,13	200
6RN200L02E25	IE2	37	2960	66	38	0,88	92,5	92,8	7,4	2,7	3,5	119	0,15	225
6RN225M02E22	IE2	45	2965	79	46	0,88	92,9	93,1	7,8	2,7	3,7	145	0,23	295
6RN250M02E22	IE2	55	2970	96	55	0,89	93,2	93,3	6,8	2,3	3,1	177	0,40	360
6RN280S02E20	IE2	75	2978	133	77	0,87	93,8	93,6	7,2	2,5	3,2	240	0,71	490
6RN280M02E22	IE2	90	2975	157	91	0,88	94,1	94,2	7,1	2,5	3,1	289	0,83	530
6RN315S02E20	IE2	110	2982	187	108	0,90	94,3	94,2	7,3	2,4	3,0	352	1,3	720
6RN315M02E22	IE2	132	2982	220	127	0,91	94,6	94,7	7,2	2,4	3,1	423	1,6	880
6RN315L02E24	IE2	160	2982	265	153	0,92	94,8	94,9	7,0	2,3	3,1	512	1,8	930
6RN315L02E25	IE2	200	2982	330	191	0,92	95,0	95,2	7,1	2,4	3,0	640	2,2	1130
RNN315L02E25	IE2	250	2979	420	242	0,9	95,7	95,8	7	1,8	2,8	801	2,7	1300
RNN315L02E27	IE2	315	2979	520	300	0,91	96	96,1	7	1,8	2,8	1010	3,3	1500
RNN355M02E23	IE2	355	2980	590	341	0,9	96	96,1	6,5	1,7	2,5	1140	4,8	1900
RNN355L02B5	-	400	2980	660	381	0,91	96,2	96,3	6,5	1,7	2,5	1280	5,3	2000
RNN355L02B7	-	500	2982	820	473	0,91	96,6	96,7	6,5	1,8	2,6	1600	6,4	2200
RNN400M02B3	-	560	2985	920	531	0,91	96,6	96,7	7	1,6	2,8	1790	8,6	2800
RNN400L02B5	-	630	2985	1040	600	0,91	96,6	96,7	7	1,6	2,8	2020	9,6	3000
RNN400L02B7	-	710	2985	-	670	0,91	96,8	96,9	7	1,7	2,8	2270	11	3200
RNN450M02B3	-	800	2986	-	760	0,91	96,7	96,8	7	0,9	3	2560	19	4000
RNN450L02B5	-	900	2986	-	840	0,92	96,8	96,9	7	0,9	2,8	2880	21	4200
RNN450L02B7	-	1000	2986	-	920	0,93	96,9	97	7	0,9	2,7	3200	23	4400

IEC housing size	Complies with	Power	Speed	Nominal current	Nominal current	Power Factor	Efficiency	Efficiency	Starting current	Starting torque	Stall torque	Nominal torque	Mass inertia J	Mass
Type		kW	min ⁻¹	at 400 V	at 690 V	cos φ	4/4 load %	3/4 load %	Ia/In	Ma/Mn	Mk/Mn	Nm	kgm ²	kg
<i>4 polig synchron loerental 1500 min⁻¹</i>														
RN63M04K	-	0,12	1395	0,41	-	0,65	66		3,5	2,7	2,6	0,82	0,00037	4,1
RN63M04	-	0,18	1395	0,59	-	0,68	65		3,6	3	2,5	1,3	0,00045	5,1
RN71M04K	-	0,25	1410	0,81	-	0,64	70		4,3	3,6	3,1	1,7	0,00076	6
RN71M04	-	0,37	1385	1,04	-	0,73	71		4,2	3,3	3	2,6	0,00095	7,2
RN80M04K	-	0,55	1410	1,32	-	0,78	77		5,6	3,4	2,9	3,7	0,0017	9,8
RN80M04E2	IE2	0,75	1400	1,81	-	0,75	79,6	79,6	5,8	4	3,5	5,1	0,0024	12,3
RN90S04E2	IE2	1,1	1440	2,55	-	0,77	81,4	81,4	6,4	3,1	3,2	7,3	0,0033	15
RN90L04E2	IE2	1,5	1440	3,4	-	0,77	82,8	82,8	6,7	3,6	3,4	9,9	0,004	18
RN100L04E2K	IE2	2,2	1455	4,65	-	0,81	84,3	84,6	6,9	2,1	3,3	14	0,0086	21
RN100L04E2	IE2	3	1455	6,2	3,58	0,82	85,5	85,9	6,9	2	3,1	20	0,0109	25
RN112M04E2	IE2	4	1460	8,2	4,73	0,81	86,6	86,7	7,1	2,5	3,2	26	0,014	29
RN132S04E2	IE2	5,5	1465	11,4	6,58	0,8	87,7	87,9	6,9	2,3	2,9	36	0,02698	42
RN132M04E2	IE2	7,5	1465	14,8	8,54	0,83	88,7	89,2	6,9	2,3	2,9	49	0,03353	49
RN160M04E2	IE2	11	1470	21	12,1	0,85	89,8	90,3	6,7	2,2	2,8	71	0,06495	71
RN160L04E2	IE2	15	1475	28	16,2	0,85	90,6	90,8	7,3	2,5	3	97	0,08281	83
6RN180M04E22	IE2	18,5	1465	35	20	0,84	91,2	92,0	7,2	2,5	3,4	121	0,12	160
6RN180L04E24	IE2	22	1465	41,5	24	0,84	91,6	92,2	7,3	2,6	3,5	143	0,13	170
6RN200L04E25	IE2	30	1470	56	32	0,84	92,3	92,8	6,7	2,5	3,3	195	0,20	230
6RN225S04E20	IE2	37	1470	65	38	0,88	92,7	93,5	6,6	2,3	2,9	240	0,42	280
6RN225M04E22	IE2	45	1475	80	46	0,87	93,1	93,8	6,9	2,5	3,1	291	0,46	305
6RN250M04E22	IE2	55	1480	100	58	0,85	93,5	93,9	6,8	2,7	3,0	355	0,85	
6RN280S04E20	IE2	75	1485	132	76	0,87	94,0	94,2	6,8	2,5	3,0	482	1,3	550
6RN280M04E22	IE2	90	1486	159	92	0,87	94,2	94,3	7,3	2,6	3,1	578	1,4	570
6RN315S04E20	IE2	110	1490	195	113	0,86	94,5	94,6	7,4	2,7	3,0	705	2,0	740
6RN315M04E22	IE2	132	1490	230	133	0,87	94,7	94,9	7,1	2,7	2,9	847	2,3	870
6RN315L04E24	IE2	160	1490	280	162	0,87	94,9	95,0	7,2	2,8	3,1	1025	2,8	940
6RN315L04E25	IE2	200	1490	350	202	0,87	95,1	95,3	7,5	3,1	3,2	1282	3,5	1140
RNN315L04E25	IE2	250	1488	435	251	0,87	95,5	95,6	6,5	1,9	2,8	1600	3,6	1300
RNN315L04E27	IE2	315	1488	550	318	0,87	95,7	95,8	6,8	2	2,8	2020	4,4	1500
RNN355M04E23	IE2	355	1488	610	352	0,87	95,8	95,9	6,5	2,1	2,6	2280	6,1	1900
RNN355L04B5	-	400	1488	690	398	0,87	95,9	96	6,5	2,1	2,6	2570	6,8	2000
RNN355L04B7	-	500	1488	850	491	0,88	96,2	96,3	6,5	2,1	2,4	3210	8,5	2200
RNN400M04B3	-	560	1492	950	548	0,88	96,2	96,3	6,5	1,9	2,7	3580	13	2800
RNN400L04B5	-	630	1492	1080	624	0,88	96,4	96,5	6,8	1,9	2,7	4030	14	3000
RNN400L04B7	-	710	1492	-	670	0,89	96,5	96,6	6,8	1,9	2,7	4540	16	3200
RNN450M04B3	-	800	1492	-	760	0,88	96,5	96,6	7	1,6	2,6	5120	23	4000
RNN450L04B5	-	900	1492	-	840	0,88	96,6	96,7	7	1,6	2,6	5760	26	4200
RNN450L04B7	-	1000	1492	-	920	0,89	96,6	96,7	7	1,7	2,6	6400	28	4400

RN Series 3-phase Motor Electric Data

IEC housing size	Complies with	Power	Speed	Nominal current	Nominal current	Power Factor	Efficiency	Efficiency	Starting current	Starting torque	Stall torque	Nominal torque	Mass inertia J	Mass
Type		kW	min ⁻¹	at 400 V	at 690 V	cos φ	4/4 load %	3/4 load %	Ia/In	Ma/Mn	Mk/Mn	Nm	kgm ²	kg
<i>6 pole synchronous torerental 1000 min⁻¹</i>														
RN71M06K	-	0.18	830	1.12	-	0.33	54.4		2.5	1.9	1.9	2.0	0.00055	6
RN71M06	-	0.25	830	1.4	-	0.43	58.7		2.7	2	2	2.9	0.0008	7
RN80M06K	-	0.37	910	2.18	-	0.63	59.4		3.1	1.8	1.9	3.9	0.0014	9
RN80M06	-	0.55	885	3.05	-	0.88	61.1		3	1.8	2	5.9	0.0017	10
RN90S06E2	IE2	0.75	925	1.98	-	0.72	75.9	75.9	4.4	3	2.5	7.7	0.0033	15.7
RN90L06E2	IE2	1.1	940	2.9	-	0.7	78.1	78.1	5.7	3.7	3.2	11	0.005	19
RN100L06E2	IE2	1.5	970	3.7	-	0.73	79.8	79.8	6.2	2	2.9	15	0.0113	25
RN112M06E2	IE2	2.2	965	5.2	-	0.75	81.8	81.8	6	2.1	3.1	22	0.0139	29
RN132S06E2	IE2	3	970	7	4.04	0.74	83.3	83.3	5.6	1.6	2.6	30	0.02371	38
RN132M06E2K	IE2	4	970	8.7	5.02	0.78	84.6	84.6	5.6	1.6	2.5	39	0.02918	43
RN132M06E2	IE2	5.5	970	12	6.93	0.77	86	86	6.1	1.9	2.8	54	0.03673	52
RN160M06E2	IE2	7.5	975	16.2	9.35	0.77	87.2	87.2	6.3	1.8	2.8	73	0.0754	77
RN160L06E2	IE2	11	975	22.5	13.0	0.8	88.7	88.4	6.2	1.7	2.7	108	0.0975	93
6RN180L06E24	IE2	15	975	31	18	0.78	89.7	90.1	6.0	2.5	3.1	147	0.17	155
6RN200L06E24	IE2	18.5	978	36	21	0.82	90.4	91.3	5.8	2.4	2.6	181	0.25	200
6RN200L06E25	IE2	22	978	42.5	25	0.82	90.9	91.6	6.2	2.5	2.6	215	0.30	220
6RN225M06E22	IE2	30	980	57	33	0.83	91.7	92.5	6.1	2.5	2.8	292	0.58	285
6RN250M06E22	IE2	37	982	70	40	0.83	92.2	93.1	6.0	2.8	2.5	360	0.86	370
6RN280S06E20	IE2	45	985	83	48	0.84	92.7	93.4	6.3	2.7	2.6	436	1.1	460
6RN280M06E22	IE2	55	985	99	57	0.86	93.1	93.9	6.4	2.5	2.6	533	1.4	510
6RN316S06E20	IE2	75	988	138	80	0.84	93.7	94.0	6.7	2.5	2.8	725	2.1	660
6RN315M06E22	IE2	90	988	165	95	0.84	94.0	94.3	6.9	2.6	2.8	870	2.5	730
6RN315L06E24	IE2	110	988	196	113	0.86	94.3	94.6	7.0	2.7	2.8	1063	3.6	920
6RN315L06E25	IE2	132	988	235	136	0.86	94.6	94.9	7.5	3.0	2.9	1276	4.0	990
RNN315L06E25	IE2	200	988	355	205	0.86	95.2	95.5	6.3	2	2.5	1930	6	1300
RNN315L06E27	IE2	250	988	440	254	0.86	95.4	95.6	6.3	2	2.5	2410	7.3	1500
RNN355L06E25	IE2	315	993	550	318	0.86	95.7	95.8	6.5	2.2	2.8	3040	13	2000
RNN355L06B7	-	400	993	700	404	0.86	96	96.1	6.5	2.2	2.8	3850	16	2200
RNN400M06B3	-	450	991	790	456	0.86	96	96.1	6.5	2.2	2.8	4330	21	2800
RNN400L06B5	-	500	991	870	502	0.86	96	96.1	6.5	2.3	2.8	4810	24	3000
RNN400L06B7	-	560	991	980	566	0.86	96.2	96.3	6.5	2.3	2.8	5390	27	3200
RNN450M06B3	-	630	993	1100	635	0.86	96.3	96.4	6.5	2	2.6	6060	35	4000
RNN450L06B5	-	710	993	-	720	0.86	96.3	96.4	6.5	2	2.5	6830	39	4200
RNN450L06B7	-	800	993	-	810	0.86	96.5	96.7	6.5	2	2.5	7690	44	4500

IEC housing size	Complies with	Power	Speed	Nominal current	Nominal current	Power Factor	Efficiency	Efficiency	Starting current	Starting torque	Stall torque	Nominal torque	Mass inertia J	Mass
Type		kW	min ⁻¹	at 400 V	at 690 V	cos φ	4/4 load %	3/4 load %	Ia/In	Ma/Mn	Mk/Mn	Nm	kgm ²	kg
<i>8 pole synchronous torerental 1500 min⁻¹</i>														
RN63M08	-	0.04	640	0.29	-	0.63	32		1.6	1.7	1.9	0.6	0.00037	5
RN71M08K	-	0.09	630	0.36	-	0.68	53		2.2	1.9	1.7	1.4	0.0008	7
RN71M08	-	0.12	645	0.51	-	0.68	53		2.2	2.2	2	1.8	0.0008	7
RN80M08K	-	0.18	675	0.75	-	0.64	51		2.3	1.7	1.9	2.5	0.0014	8
RN80M08	-	0.25	680	1.03	-	0.61	55		2.6	2	2	3.5	0.0017	10
RN90S08	-	0.37	675	1.13	-	0.75	63		2.9	1.6	1.8	5.2	0.0023	13
RN90L08	-	0.55	675	1.58	-	0.76	66.5		3	1.7	1.9	8	0.0031	14
RN100L08K	-	0.75	725	2.75	-	0.58	68	65	4	1.6	2.8	9.9	0.0086	21
RN100L08	-	1.1	725	4.05	-	0.58	68	64.5	4	1.8	2.8	14	0.0109	25
RN112M08	-	1.5	720	4.2	-	0.67	77	75.5	4.2	1.4	2.4	20	0.014	29
RN132S08	-	2.2	725	6.5	-	0.63	77.5	76.7	3.6	1.4	1.8	29	0.02698	41
RN132M08	-	3	730	7.9	4.56	0.65	84	82	5	1.4	2.4	40	0.03463	49
RN160M08K	-	4	730	9.6	5.54	0.69	87	88	4.3	1.8	2	52	0.0649	69
RN160M08	-	5.5	735	13.2	7.62	0.69	87.5	89	4.4	2.1	2.1	72	0.0828	82
RN160L08	-	7.5	730	17	9.81	0.72	88	89	4.5	1.9	2.1	98	0.0982	94
6RN180L08E14	-	11	720	26	15	0.7	86.6	87.6	4.9	2.3	2.6	146	0.2	15
6RN200L08E15	-	15	718	32	18.5	0.76	88.9	90.8	5.4	2.4	2.8	200	0.34	22
6RN225S08E10	-	18.5	730	38.5	22	0.78	89	89.9	5.4	2.2	2.7	242	0.43	25
6RN225M08E12	-	22	730	44	25	0.8	90.3	91.3	5.5	2.3	2.7	288	0.5	27
6RN250M08E12	-	30	732	59	34	0.8	91.3	92.2	5.6	2.4	2.7	391	0.86	37
6RN280S08E10	-	37	736	75	43	0.78	91.9	92.5	5.4	2.3	2.4	480	1.1	460
6RN280M08E12	-	45	738	89	51	0.79	92.4	92.8	5.7	2.5	2.5	582	1.4	510
6RN315S08E10	-	55	740	107	62	0.8	92.9	93.3	5.8	2.2	2.6	710	2	640
6RN315M08E12	-	75	738	143	83	0.81	93.5	94.4	5.8	2.2	2.6	970	2.5	710
6RN315L08E14	-	90	740	167	96	0.83	93.5	94.3	5.8	2.2	2.5	1161	3.1	860
6RN315L08E15	-	110	740	205	118	0.82	94.2	95	6.4	2.4	2.8	1420	3.9	980
6RN315L08E16	-	132	740	250	144	0.81	94.4	94.8	7.1	2.7	3.1	1703	4.5	1060
RNN315L08B5	-	160	739	300	173.2	0.82	94.4	94.5	6	2.1	2.3	2070	6	1300
RNN315L08B7	-	200	739	370	213.6	0.82	94.7	94.8	6	2.1	2.3	2580	7.3	1500
RNN355L08B5	-	250	741	460	266	0.82	95.2	95.3	6.1	2.1	2.4	3220	13	2000
RNN355L08B7	-	315	741	580	335	0.82	95.5	95.6	6.1	2.1	2.4	4060	16	2200
RNN400M08B3	-	355	742	650	375	0.82	95.6	95.7	6.5	2	2.6	4570	21	2800
RNN400L08B5	-	400	742	740	427	0.82	95.7	95.8	6.5	2.1	2.6	5150	24	3000
RNN400L08B7	-	450	742	830	479	0.82	95.8	95.9	6.5	2.1	2.6	5790	27	3200
RNN450M08B3	-	500	744	930	537	0.81	95.9	96	6.6	2	2.4	6420	35	4000
RNN450L08B5	-	560	744	1040	600	0.81	96	96.1	6.6	2	2.4	7190	39	4200
RNN450L08B7	-	630	744	1160	670	0.81	96.1	96.2	6.6	2	2.4	8090	44	4500

RN-IE3 Series 3-phase Motor Electric Data

IEC housing size Type	Complies with	Power kW	Speed min ⁻¹	Nominal current at 400 V	Nominal current at 690 V	Power Factor cos φ	Efficiency 4/4 load %	Efficiency 3/4 load %	Starting current I _a /I _n	Starting torque M _a /M _n	Stall torque M _k /M _n	Nominal torque Nm	Mass inertia J kgm ²	Mass kg
6RN180M02E32	IE3	22	2950	38,5	22	0,89	92,7	93,0	7,5	2,5	3,5	71	0,080	160
6RN200L02E34	IE3	30	2955	53	31	0,87	93,3	93,7	6,6	2,5	3,3	97	0,13	225
6RN200L02E35	IE3	37	2955	65	38	0,88	93,7	94,1	6,6	2,5	3,2	120	0,16	250
6RN225M02E32	IE3	45	2960	78	45	0,89	94,0	94,5	6,9	2,4	3,3	145	0,26	315
6RN250M02E32	IE3	55	2975	95	55	0,89	94,3	94,5	6,7	2,3	3,1	177	0,46	385
6RN280S02E30	IE3	75	2975	128	74	0,89	94,7	94,8	6,8	2,4	3,0	241	0,77	510
6RN280M02E32	IE3	90	2975	152	88	0,90	95,0	95,1	7,2	2,4	3,1	289	0,94	590
6RN315S02E30	IE3	110	2982	183	106	0,91	95,2	95,4	7,1	2,4	3,1	352	1,4	750
6RN315M02E32	IE3	132	2982	220	127	0,91	95,4	95,5	7,2	2,5	3,1	423	1,6	880
6RN315L02E34	IE3	160	2982	265	153	0,92	95,6	95,7	7,8	2,8	3,3	512	1,9	980
6RN315L02E35	IE3	200	2982	330	191	0,92	95,8	95,9	7,2	2,5	3,0	640	2,3	1150

IEC housing size Type	Complies with	Power kW	Speed min ⁻¹	Nominal current at 400 V	Nominal current at 690 V	Power Factor cos φ	Efficiency 4/4 load %	Efficiency 3/4 load %	Starting current I _a /I _n	Starting torque M _a /M _n	Stall torque M _k /M _n	Nominal torque Nm	Mass inertia J kgm ²	Mass kg
<i>1500 min⁻¹, 4-polig, 50Hz</i>														
6RN180M04E32	IE3	18,5	1470	35	20	0,82	92,6	93,2	6,9	2,5	3,3	120	0,13	165
6RN180L04E34	IE3	22	1470	41	24	0,83	93,0	93,7	6,8	2,5	3,3	143	0,14	170
6RN200L04E35	IE3	30	1470	55	32	0,84	93,6	94,3	6,9	2,6	3,1	195	0,22	240
6RN225S04E30	IE3	37	1478	66	38	0,86	93,9	94,5	6,4	2,5	2,7	239	0,42	285
6RN225M04E32	IE3	45	1478	80	46	0,86	94,2	94,9	6,4	2,6	2,7	291	0,47	320
6RN250M04E32	IE3	55	1482	96	55	0,87	94,6	95,1	6,8	2,5	2,9	354	0,85	420
6RN280S04E30	IE3	75	1485	133	77	0,86	95,0	95,3	6,9	2,5	3,0	482	1,4	570
6RN280M04E32	IE3	90	1485	157	91	0,87	95,2	95,5	7,2	2,6	3,0	579	1,7	670
6RN315S04E30	IE3	110	1488	191	110	0,87	95,4	95,8	6,8	2,6	2,9	706	2,2	760
6RN315M04E32	IE3	132	1490	230	133	0,87	95,6	95,9	7,3	2,8	3,0	846	2,9	960
6RN315L04E34	IE3	160	1490	275	159	0,87	95,8	96,1	7,3	2,9	3,1	1025	3,1	990
6RN315L04E35	IE3	200	1488	340	196	0,88	96,0	96,3	7,4	3,2	3,0	1284	3,7	1190

IEC housing size Type	Complies with	Power kW	Speed min ⁻¹	Nominal current at 400 V	Nominal current at 690 V	Power Factor cos φ	Efficiency 4/4 load %	Efficiency 3/4 load %	Starting current I _a /I _n	Starting torque M _a /M _n	Stall torque M _k /M _n	Nominal torque Nm	Mass inertia J kgm ²	Mass kg
<i>1000 min⁻¹, 6-polig, 50Hz</i>														
6RN180L06E34	IE3	15	975	29,5	17	0,80	91,2	91,9	5,9	2,3	2,8	147	0,19	180
6RN200L06E34	IE3	18,5	978	37	21	0,79	91,7	92,5	5,6	2,5	2,6	181	0,28	215
6RN200L06E35	IE3	22	978	43,5	25	0,79	92,2	93,0	5,6	2,5	2,6	215	0,32	230
6RN225M06E32	IE3	30	982	56	32	0,83	92,9	93,6	6,6	2,6	3,0	292	0,67	325
6RN250M06E32	IE3	37	985	67	39	0,85	93,3	94,0	7,0	2,7	2,9	359	1,0	405
6RN280S06E30	IE3	45	988	82	47	0,85	93,7	94,3	6,8	3,0	2,8	435	1,4	510
6RN280M06E32	IE3	55	988	99	57	0,85	94,1	94,6	7,2	3,2	3,0	532	1,6	560
6RN315S06E30	IE3	75	992	136	79	0,80	94,6	94,9	7,3	2,6	3,1	723	2,6	750
6RN315M06E32	IE3	90	990	161	93	0,83	94,9	95,3	6,7	2,5	2,8	867	3,1	890
6RN315L06E34	IE3	110	991	199	115	0,84	95,1	95,5	7,2	2,8	3,0	1060	3,9	990
6RN315L06E35	IE3	132	991	240	139	0,84	95,4	95,9	7,2	2,7	3,0	1272	4,4	1110
6RN315L06E36	IE3	160	991	290	167	0,83	95,6	95,8	7,7	3,3	3,5	1542	4,6	1160

Standard line 3-phase Electric Motors with Increased Power/Extended Stator Pack

IEC housing size	Complies with	Power	Speed	Nominal current	Nominal current	Power factor	Efficiency	Efficiency	Starting current	Starting torque	Kip torque	Nominal torque	Mass inertia J	Mass
Type		kW	min ⁻¹	at 400 V	at 690 V	cos φ	4/4 load %	3/4 load %	Ia/In	Ma/Mn	Mk/Mn	Nm	kgm ²	kg
<i>2-pole synchronous speed 3,000 min⁻¹ increased power</i>														
RN63M02V	-	0.45	2,720	1.89	1.09	0.88	67		4.2	2	2	1.58	0.00026	5
RN71M02V	-	0.94	2,730	3.83	2.21	0.84	73.3		4.8	3.1	3.7	3.29	0.00045	7
RN80M02V	-	1.75	2,835	7.1	4.1	0.78	78.4		7	4.2	4.2	5.9	0.0013	14
RN90L02V	-	3.8	2,780	8	4.65	0.84	80.9		6	3.1	3.4	13.1	0.0022	20
RN100L02E2V	IE2	4	2,905	7.8	4.5	0.86	85.8	86.3	7.6	2.5	3.5	13	0.0054	26
RN112M02E2V	IE2	5.5	2,950	10.3	5.95	0.89	87	86.7	7.7	2.2	3.3	17.8	0.0119	34
RN132M02E2V	IE2	11	2,955	20	11.5	0.89	89.4	90	8.2	2.5	3.2	35.5	0.03143	57
RN160L02E2V	IE2	22	2,955	39	22.5	0.89	91.3	91.7	8.4	3.1	3.7	71	0.06764	94
RN200L02E28	IE2	45	2,960	79	45.6	0.89	92.9	92.9	7.3	2.6	3.3	145	0.22	300
RN225M02E28	IE2	55	2,965	96	55.4	0.89	93.2	93.3	7.9	3	3.3	177	0.32	390
RN250M02E28	IE2	75	2,975	130	75.1	0.89	93.8	94	7.6	2.5	3.1	241	0.57	470
RN280M02E28	IE2	110	2,978	187	108	0.9	94.3	94.6	7.8	2.8	3.3	353	1.2	660
RN315L02E28	IE2	250	2,986	415	240	0.91	95	94.9	8.3	3.2	3.5	800	2.6	1,280
RN315L02E29	IE2	315	2,986	540	312	0.89	95	94.7	9.2	3.4	3.8	1,007	2.8	1,355

IEC housing size	Complies with	Power	Speed	Nominal current	Nominal current	Power factor	Efficiency	Efficiency	Starting current	Starting torque	Kip torque	Nominal torque	Mass inertia J	Mass
Type		kW	min ⁻¹	at 400 V	at 690 V	cos φ	4/4 load %	3/4 load %	Ia/In	Ma/Mn	Mk/Mn	Nm	kgm ²	kg
<i>4-pole synchronous speed 1,500 min⁻¹ increased power</i>														
RN63M04V	-	0.29	1,320	1.65	0.95	0.75	58.1		2.9	2.1	2.1	2.1	0.00045	5
RN71M04V	-	0.6	1,350	2.75	1.6	0.78	70		4.1	2.4	2.4	4.24	0.00095	7
RN80M04V	-	1.25	1,382	5.15	3	0.81	74.7		4.7	2.8	2.9	8.64	0.0024	14
RN90L04V	-	2.5	1,360	5.9	3.41	0.8	75.8		4.5	2.8	2.8	17.6	0.004	17.5
RN100L04E2V	IE2	4	1,460	8.34	4.82	0.8	86.6	86.6	7.5	2.2	3.5	26.1	0.0137	26.2
RN112M04E2V	IE2	5.5	1,460	11.2	6.47	0.81	87.7	87.7	7.1	2.5	3.1	34.2	0.0166	34
RN132M04E2V	IE2	11	1,465	21	12.1	0.84	89.8	89.8	7.7	2.9	3.4	71.7	0.04571	64
RN160L04E2V	IE2	18.5	1,475	34.5	19.9	0.85	91.2	91.2	7.7	2.8	3.3	119	0.09854	143
RN225M04E28	IE2	55	1,482	99	57.2	0.86	93.5	93.9	7	2.8	3	354	0.66	355
RN250M04E28	IE2	75	1,485	132	76.2	0.87	94	94.4	7.3	2.6	2.9	482	0.99	495
RN280M04E28	IE2	110	1,486	195	113	0.86	94.5	94.6	7.5	2.7	3.1	707	1.9	710
RN315L04E28	IE2	250	1,488	435	251	0.87	95.1	94.7	7.7	3.1	3.1	1,605	4.2	1,290
RN315L04E29	IE2	315	1,488	560	323	0.86	95.1	94.4	7.7	3.1	3.1	2,022	5	1,500

IEC housing size	Complies with	Power	Speed	Nominal current	Nominal current	Power factor	Efficiency	Efficiency	Starting current	Starting torque	Kip torque	Nominal torque	Mass inertia J	Mass
Type		kW	min ⁻¹	at 400 V	at 690 V	cos φ	4/4 load %	3/4 load %	Ia/In	Ma/Mn	Mk/Mn	Nm	kgm ²	kg
<i>6-pole synchronous speed 1,000 min⁻¹ increased power</i>														
RN63M06V	-	0.12	890	1.2	0.64	0.61	45		2.1	2.2	2.1	1.29	0.00045	5
RN90L06V	-	1.5	850	7.1	4.1	0.79	67		3.6	2.4	2.1	16.9	0.0044	19
RN100L06V	IE2	2.2	965	5.1	2.94	0.76	81.8	82.5	5.7	1.9	2.9	22	0.0137	30
RN112M06V	IE2	3	960	6.6	3.81	0.79	83.3	83.4	6	2.1	3.1	30	0.0166	34
RN132M06V	IE2	7.5	970	16.1	9.3	0.77	87.2	87.2	6.5	2.1	3	74	0.04572	64
RN160L06V	IE2	15	975	30	17.3	0.81	89.7	89.9	6.5	1.9	2.9	147	0.1208	115
RN225M06E28	IE2	37	980	68	39.3	0.84	92.2	93.1	6.7	2.8	2.9	361	0.76	355
RN250M06E28	IE2	45	985	84	48.5	0.83	92.7	93.6	6.9	2.9	2.5	436	1.1	435
RN280M06E28	IE2	75	988	136	78.5	0.85	93.7	94.3	7.3	3.3	2.8	725	1.9	615
RN315L06E28	IE2	160	990	285	165	0.86	94.8	94.9	7.8	3.2	3.1	1,543	5.4	1,245
RN315L06E29	IE2	200	990	365	211	0.83	95	95.1	7.9	2.8	3.1	1,929	5.72	1,395

IEC housing size	Complies with	Power	Speed	Nominal current	Nominal current	Power factor	Efficiency	Efficiency	Starting current	Starting torque	Kip torque	Nominal torque	Mass inertia J	Mass
Type		kW	min ⁻¹	at 400 V	at 690 V	cos φ	4/4 load %	3/4 load %	Ia/In	Ma/Mn	Mk/Mn	Nm	kgm ²	kg
<i>8-pole synchronous speed 750 min⁻¹ increased power</i>														
RN90L08V	-	0.75	670	2.21	1.3	0.72	70		3	2	2	11	0.0051	16
RN112M08V	-	2.2	695	6.2	3.6	0.71	73		3.9	2.2	2.3	30	0.019	42
RN132M08V	-	4	690	11.5	6.6	0.68	74		3.9	2.2	2.4	55	0.025	74
RN180L08B8	-	15	720	34	19.6	0.73	88		4.5	2	2.4	199	0.206	165
RN200L08B8	-	18.5	725	39.5	22.8	0.78	88.5		5.5	2.5	2.6	244	0.367	230
RN225M08B8	-	30	730	61	35.2	0.79	90.5		6	2.5	2.8	392	0.73	345
RN250M08B8	-	37	731	72	41.6	0.82	92		5.9	2.3	2.6	483	1.061	130
RN280M08B8	-	55	736	106	61.2	0.81	93		5.9	2.4	2.3	714	1.63	560
RN315L08B8	-	132	740	240	139	0.84	94.9	95.2	6.7	2.5	2.9	1,704	5.3	1,270
RN315L08B9	-	160	738	300	173	0.81	94.6	95.1	6.8	2.7	2.9	2,070	7.2	1,380

Single-phase Electric Motors RCC and RC

IEC Housing size type	Power kW	Rotational speed min ⁻¹	Nominal current at 230 V A	Power factor cos φ -	Efficiency %	Starting current Ia/In -	Starting torque Ma/Mn -	Stall torque Mk/Mn -	Capacitor 450 V~		Mass kg
									μF	μF	
2-pole synchronous rotational speed 3,000 min⁻¹											
RCC63-2K	0.18	2,880	1.4	0.87	62	5.2	1.9	2.6	6	25	5
RCC63-2	0.25	2,860	1.6	0.99	68	4.7	1.6	2.0	8	25	5.5
RCC71-2K	0.37	2,800	2.7	0.96	63	3.9	1.7	1.7	10	40	5.7
RCC71-2	0.55	2,820	3.6	0.95	71	4.0	1.7	1.7	12	40	6.6
RCC80-2K	0.75	2,845	4.7	0.98	71	4.1	1.7	1.6	18	60	10.2
RCC80-2	1.1	2,860	6.7	0.98	73	4.4	1.7	1.8	25	80	11.9
RCC90S-2	1.5	2,845	9.2	0.98	72	4.5	2.0	2.0	35	120	15.2
RCC90L-2	2.2	2,830	13.3	0.97	74	4.8	1.9	2.2	40	160	18
RCC100L-2	3	2,840	17.5	0.97	77	5.3	2.1	2.5	60	180	25
4-pole synchronous rotational speed 1,500 min⁻¹											
RCC63-4K	0.12	1,415	1.0	0.91	58	3.7	1.8	1.7	4	16	4.9
RCC63-4	0.18	1,410	1.4	0.90	62	3.4	1.9	1.7	6	25	5.8
RCC71-4K	0.25	1,395	2.0	0.98	55	3.2	1.7	1.6	12	25	6.5
RCC71-4	0.37	1,395	2.7	0.95	64	3.2	1.8	1.7	14	25	7.4
RCC80-4K	0.55	1,415	3.7	0.98	69	3.6	1.7	1.7	14	40	9.5
RCC80-4	0.75	1,405	4.8	0.96	71	3.9	1.9	1.6	20	60	10.3
RCC90S-4	1.1	1,420	6.6	0.98	74	3.8	1.6	1.8	30	80	14.8
RCC90L-4	1.5	1,430	8.7	0.97	77	4.3	1.9	1.8	40	120	17.4
RCC100L-4	2.2	1,395	13.4	0.98	73	4.4	2.6	1.9	60	180	28
6-pole synchronous rotational speed 1,000 min⁻¹											
RCC90S-6	0.75	955	5	0.94	70	5.2	2.5	1.8	30	80	15.5
RCC90L-6	1.1	910	7.7	0.97	65	3.2	2.2	1.7	45	80	19
RCC100L-6	1.5	930	9.6	0.98	70	3.3	1.7	1.6	50	80	26
2-pole synchronous rotational speed 3,000 min⁻¹											
RC63-2K	0.18	2,880	1.4	0.87	62	3.8	0.40	2.6	5	-	4.8
RC63-2K	0.25	2,860	1.6	0.99	68	3.7	0.48	2.0	8	-	5
RC71-2K	0.37	2,895	2.8	0.87	65	4.4	0.51	2.7	12	-	5.6
RC71-2	0.55	2,860	4.1	0.89	65	4	0.42	2.1	16	-	6.6
RC80-2K	0.75	2,905	4.5	0.97	74	5.6	0.32	2.4	16	-	8.7
RC80-2	1.1	2,910	6.3	0.98	78	6.1	0.35	2.5	25	-	11.4
RC90S-2	1.5	2,900	9.1	0.97	74	6.2	0.42	3.1	40	-	15
RC90L-2	2.2	2,810	13.6	0.98	72	4.5	0.37	1.8	50	-	18.2
RC100L-2	3	2,855	17.5	0.97	77	5.1	0.41	2.5	60	-	29
4-pole synchronous rotational speed 1,500 min⁻¹											
RC63-4K	0.12	1,415	1.0	0.91	58	2.6	0.36	1.7	4	-	5.3
RC63-4K	0.18	1,410	1.4	0.90	62	2.8	0.37	1.7	5	-	5.6
RC71-4K	0.25	1,395	2.0	0.98	55	2.1	0.60	1.6	12	-	6.2
RC71-4K	0.37	1,395	2.7	0.95	64	2.6	0.52	1.6	14	-	7
RC80-4K	0.55	1,415	3.5	0.98	69	3.0	0.50	1.7	14	-	9.7
RC80-4	0.75	1,405	4.8	0.96	71	3.1	0.40	1.9	20	-	9.9
RC90S-4	1.1	1,420	6.6	0.98	74	3.1	0.37	1.8	30	-	14
RC90L-4	1.5	1,430	8.7	0.93	75	3.7	0.35	1.8	40	-	17
RC100L-4	2.2	1,395	13.4	0.98	73	3.6	0.43	1.9	60	-	28
6-pole synchronous rotational speed 1,000 min⁻¹											
RC80-6K	0.37	900	2.9	0.93	60	2.3	0.7	1.6	16	-	9.5
RC80-6K	0.55	950	3.9	0.93	66	3.2	0.4	1.8	24	-	11
RC90-S	0.75	925	5.1	0.95	68	3.0	0.6	1.7	30	-	15
RC90L-6	1.1	910	7.7	0.97	65	2.5	0.5	1.7	45	-	18
RC100L-6	1.5	920	9.4	0.98	70	2.9	0.4	1.6	55	-	25

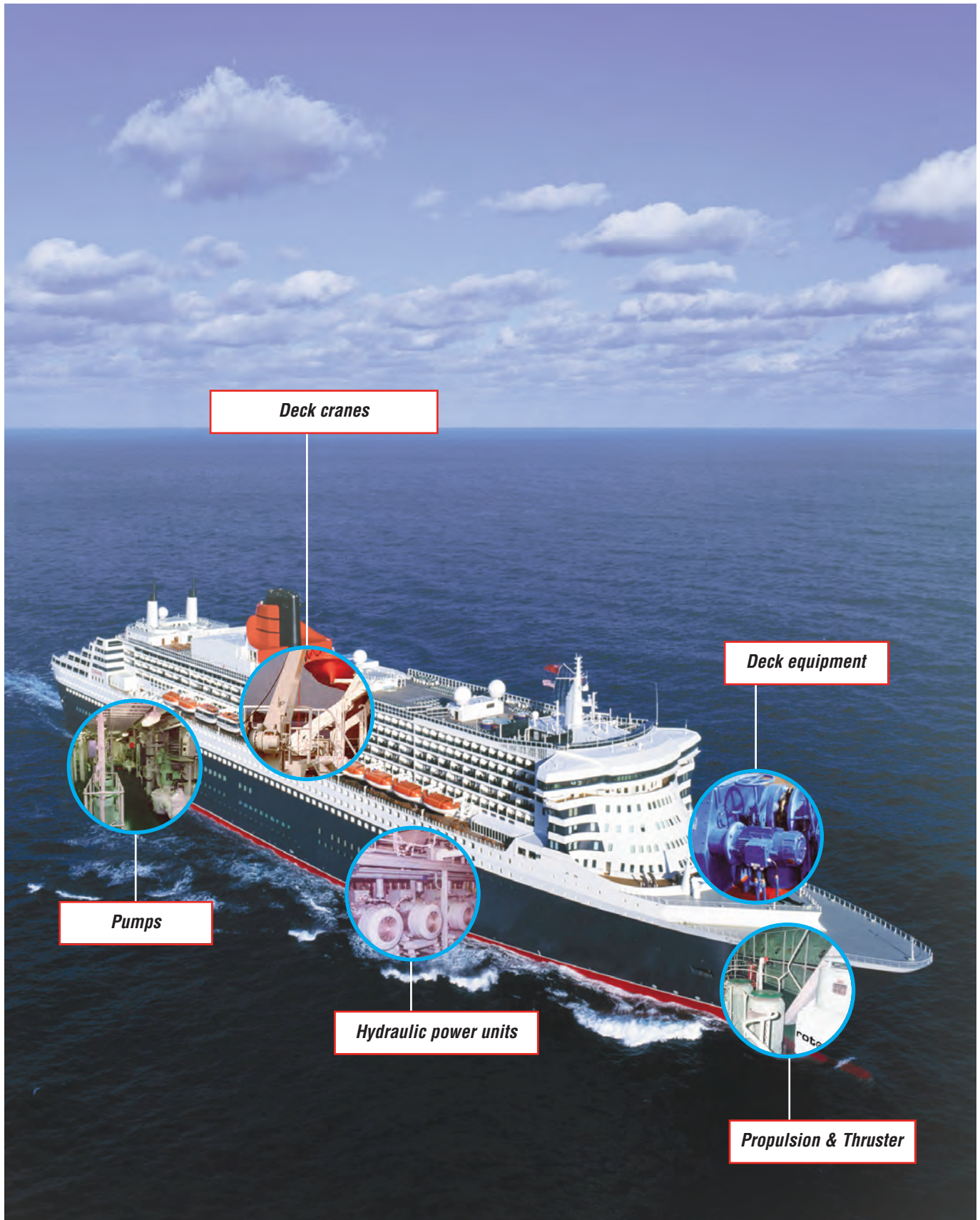

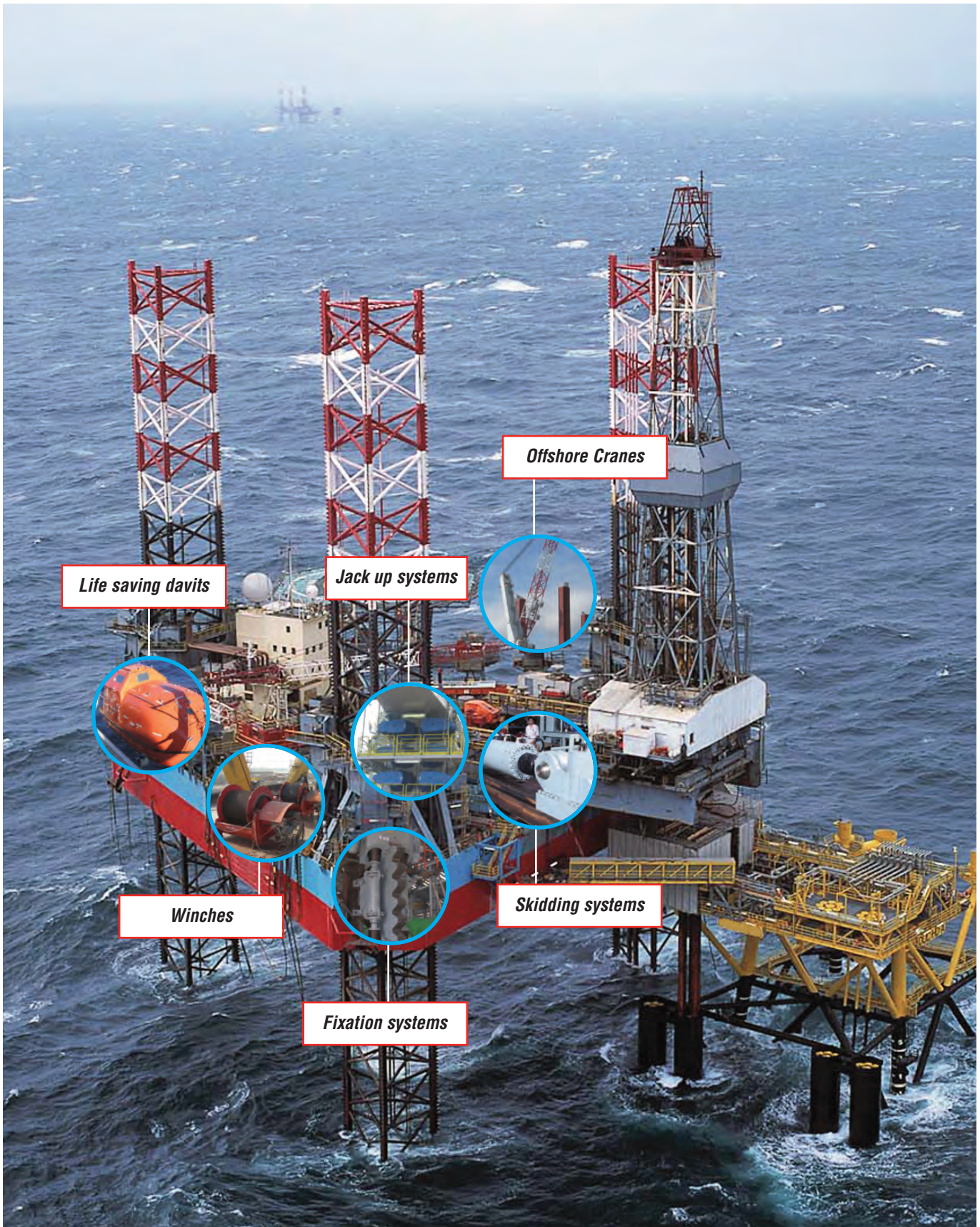

A Regal Brand

REGAL

The mechanical and electrical performance of the basic rotor nI[®] electric motors is adapted for marine and offshore application. Due to often aggressive “salty” environment, almost all sizes of RN series can be supplied in cast iron motor housing and endshields (except of very small sizes, which are in aluminium housing with cast iron endshields). Rotor produces electric motors for below deck as well as above deck applications and they can be equipped with disc brakes, encoders, force ventilation units etc. The electric motor windings are based on ambient temperatures of up to 50°C and are moisture and mould resistant suitable for relative air humidity up to 96%. These electric motors meet various criteria set out by a number of Marine Classification Societies and are suitable for “essential service” when supplied with a marine certificate.

How can a rotor nI[®] electric motor be identified as a marine motor?

All rotor nI[®] marine electric motors are equipped with stainless steel rating plate that specifies the following:

- the nominal electric motor data and the “rotor nI[®] marine classification” marking
- any additional rating plates with supplementary/customer data

The rating plate specifies the Marine Classification Society and the ambient temperature specified by the society’s regulations (usually IEC92.301 C). The date of purchase as well as the Marine Certificate number (issued by the Marine Classification Society) are also marked on the rating plate. The rating plate and a fixed component of the electric motor would have been certified and stamped by the Marine Classification Society surveyor when marine approval testing is required. Should no marine approval testing be required only the “Marine Classification Society” logo and the date of production would be specified on the rating plate. No additional rating plate would be fitted. Electric motors with a rating plate that is not marked as ‘rotor nI[®] marine classification’ are not marine motors and even though it is very likely that they would operate satisfactorily in the marine environment (on-board of a vessel or offshore), a factory marine motor declaration cannot be issued afterwards. A 2.1 or 2.2 class certificate can, in most cases, be issued for marine motors that are not older than 1 year upon request and the necessary data submission. The temperature rise of the winding must be determined by the resistance method. There are certain specific regulations applicable on marine motors related to the mechanical execution.

Certificates

All rotor nI[®] electric motors are tested after assembly to guarantee their correct operation and are subject to a high-voltage insulation test and a no-load run test. Additional tests can be performed in the factory test laboratory. Multiple electric motors can be tested there under continuous or intermittent load at the same time and their electrical and mechanical properties measured and identified. This is the same procedure as when new motor designs are tested and Type Test Reports issued. Rotor nI[®] electric motors can also be supplied with a factory Declaration of Compliance or with a Test Certificate that confirms that the test data measured on a specific electric motor are in compliance with the customer’s specification. Rotor nI[®] electric motors are tested to the EN 10204 standard and 4

different certificates can be selected (see table).

EN 10204-2.1

The Declaration of Compliance 2.1 (factory declaration) is issued based on the electric motor serial number, invoice number and the customer order number. No testing is involved when issuing this document.

EN 10204-2.2

Test Certificate 2.2 (factory issued certificate) is issued based on the electric motor data set out in the Type Test Report (when the motor prototype have been tested) amended with certain other data (historical test data). The invoice number and the customer order number are also marked in the Test Certificate. A number of motor serial numbers of the same type can be included in one Test Certificate.

EN 10204-3.1

The relevant no-load and full-load tests are carried out on specific electric motor when the Inspection Certificate 3.1 (inspection report) is issued. A request for Inspection Certificate 3.1 must be made at the point of the order placement. This test is also referred to as the “routine test” and provides a reasonable guarantee of the correct performance of the electric motor when the tested data comply with the Type Test data. The invoice number and the customer order number are also marked in the Inspection Certificate. One Inspection Certificate is issued for each electric motor.

EN 10204-3.2

Inspection Certificate 3.2 is issued based on the test witnessed by an independent inspector (classified inspection report). The inspector (surveyor) can be appointed by the customer or by ourselves. In majority of the cases the surveyor would attend the testing in our approved test laboratory. External testing by certified laboratories have to be carried out in certain cases.

Type Approval Certificate

Rotor is authorised and approved to independently test and certify electric motors up to 300 kW (without the actual presence of a surveyor). The tests are carried out in our approved test laboratory. This enables Rotor to supply electric motors for essential service quickly and with the relevant certificate. The independent testing has been arranged with a number of Classification Societies. Rotor B.V. can currently issue Type Approval Certificate for DNV, BV, CCS, Lloyd’s, ABS, GL and RMRS.

Standard	Dutch	English
EN 10204-2.1	Factory declaration	Declaration of compliance with the order 2.1
EN 10204-2.2	Factory inspection certificate	Test report 2.2.
EN 10204-3.1	Inspection report	Inspection certificate 3.1*
EN 10204-3.2	Classified inspection report	Inspection certificate 3.2

Environmental temperatures for marine motors and maximum temperature increase of the winding

marine classification	environmental temperature °C	Maximum DT winding °K at insulation class	
		F	H
IEC 34-1	40	105	135
IEC 92.301	50	90	115
American Bureau of Shipping	50	95	115
Bureau Veritas	45	100	120
China Classification Society	45	100	120
China Corperation Register	45	95	110
Det Norske Veritas	45	100	120
Germanischer Lloyd	45	100	120
Korean Register of Shipping	45	100	120
Lloyd's Register of Shipping	45	95	110
Nippon Kaji Kyokai	45	100	120
RINA	45	100	120
Russian Maritime Register	45	95	110
Russian River Register	45	95	110

The temperature increase of the winding is determined by the resistance method.
Specific regulations apply to marine motors with regard to the mechanical model.

Shipping Classification Bureaus



EN 60079-1-Ex-d (flameproof enclosure)

The flameproof enclosure must contain all components which can cause sparks, arcs or high temperatures and which in turn can cause an explosion during normal working conditions within the enclosure. The explosive gas mixture may also be present in the pressure tight enclosure, but any explosion inside the enclosure must not propagate to the outside atmosphere.

EN 60079-7-Ex-e (increased safety)

Electrical equipment designed in accordance with the protection type Ex-e must not contain any components that may cause sparks or arcs under normal working conditions and potentially act as an ignition source for an explosive gas mixture inside or in the surrounding of the equipment. The explosive gas mixture is expected to penetrate inside the electrical equipment. Ex-e is a type of protection where non-sparking/arcing material must be used.

EN 60079-15-Ex-n (non-sparking)

This type of protection is only suitable for Zone 2 hazardous area, but can apply to a large range of equipment. Generally any electrical device that does not have potentially sparking contacts, such as potentiometers, relays or switches or hot surfaces and where a water/dust tight enclosure is present, can be accommodated whilst certain guidelines are maintained.

It is compulsory to classify the work place in Zones and select ATEX 100a compliant equipment according to the identified Zones. Rotor trained staff is available to help with the selection of the suitable ATEX electric motors.

Zone	ATEX cat.	Description	Type of protection permitted.
0	1	An explosive gas mixture is present continuously or for long periods of time (>1000u per year)	Ex-ia
1	2	Probability of presence of an explosive gas mixture under normal working conditions is great (10 tot 1000u per year)	Ex-d, Ex-e, Ex-i, Ex-m, Ex-o, Ex-p, Ex-q
2	3	Probability of presence of an explosive gas mixture is small and that only for a short period of time (0 tot 10u per year)	Ex-d, Ex-e, Ex-i, Ex-m, EX-n, Ex-o, Ex-p, Ex-q

The standard range of Rotor ATEX motors consists of compressure-resistant electric motors, electric motors with increased safety, and electric motors with non-sparking equipment.

Explosive atmospheres

The following information is required for correct electric motor selection:

ATEX Gas explosion-proof electric motors:

- The ATEX Category (or Zone) and the protection method
- Temperature class
- For flameproof electric motors Ex II 2G Ex-d and Ex II 2G Ex-d(e):
- The Gas Group: A, B or C.

ATEX Dust explosion-proof electric motors:

- The ATEX Category (or Zone). For Zone 22 conductive or non-conductive dust must be specified.
- Maximum permissible surface temperature.

For all Zones (Gas and Dust) please specify:

- Whether the motor is to be frequency inverter controlled.
- Any specific model/execution is required

The ATEX directives do not apply to:

- Sea vessels and mobile offshore installations or for the equipment intended to be installed on board of sea vessels or offshore installations. They all must comply with the IMO (International Maritime Organization) convention.
- Means of transport not intended for explosive atmospheres.

Category and Area Classification

Two groups are referred to in the ATEX 95 directive: Group I and II. Both groups are subdivided into Categories. These Categories indicate whether a device or protection system can be deployed in a possibly explosive atmosphere with gas, mist or fumes (G) or with dust (D).

ATEX 95 Group I: = mining industry

group II: = other locations

- Category 1G Zone 0
- Category 2G Zone 1
- Category 3G Zone 2

Coding for Electric Motors in Gas Explosive Atmospheres

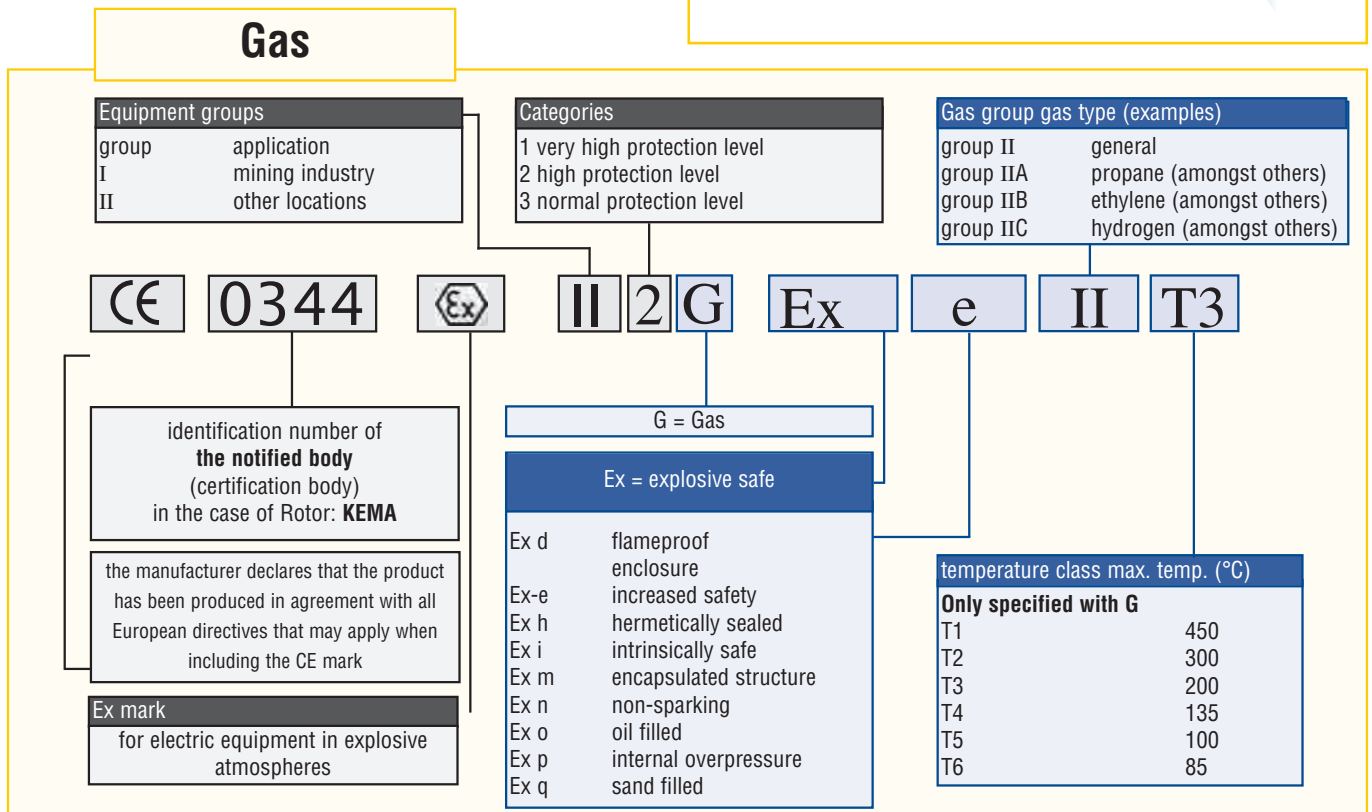
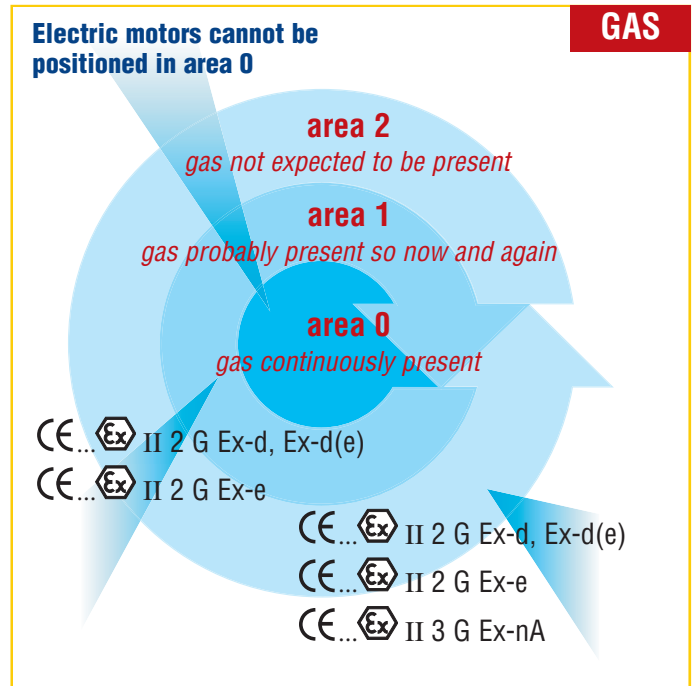



Outputs when in continuous use (S1) and at a maximum environmental temperature of 40°C.

Outputs on demand with regard to deviating environmental temperatures, intermittent operation S2, S3, etc., and deviating frequencies.

Ex-II-2G Ex-d(e)-IIc-T4 in accordance with EN 60079-0 and EN 60079-1

	Type		Power kW	Speed min-1	In (A) 400 Volt	Efficiency %	Power factor cos φ	Torque Nm	Starting torque (MA/MN)	Starting current (IA/IN)	Max. torque (MM/MN)	KR	Torque of inertia (kgmx10 ⁻⁴)	Weight kg
RD	71	B-2	0.55	2,805	1.32	70	0.86	1.87	2.9	5.5	3.1	16	4.2	16
RD	80	A-2	0.75	2,790	1.7	72	0.89	2.57	2.25	5.4	2.6	16	6.3	24
RD	80	B-2	1.1	2,790	2.35	77	0.87	3.77	2.6	6.1	2.9	16	7.9	26
RD	90	S-2	1.5	2,830	3.25	77	0.87	5.1	2.5	6.3	2.8	16	12.4	32
RD	90	L-2	2.2	2,845	4.4	82	0.88	7.4	2.8	6.9	2.65	16	15.5	34
RD	100	L-2	3	2,865	6	83.5	0.87	10	2.5	7.1	2.9	16	25.1	42.5
RD	112	M-2	4	2,890	7.8	84.5	0.88	13.2	2.5	7.6	2.95	16	45.1	58
RD	132	SA-2	5.5	2,910	10.8	84.5	0.88	18.1	2.7	6.6	2.8	16	96.7	77
RD	132	SB-2	7.5	2,925	14.5	85.5	0.89	24.5	2.7	7.9	3.1	16	122.5	84
RD	160	MA-2	11	2,840	22.3	80.6	0.88	35.8	2.8	6.9	3	16	294.3	148
RD	160	MB-2	15	2,940	28.5	83	0.92	48.9	3	7.7	3.2	16	391.2	166
RD	160	L-2	18.5	2,945	32.4	98.1	0.91	60.1	3.3	8	3	16	459	178
RD	180	M-2	22	2,930	39	92	0.89	71.7	2.4	7.2	2.9	16	615.1	205
RD	200	LA-2	30	2,930	53	93	0.88	97.8	2.1	7.3	2.8	16	1,044.2	240
RD	200	LB-2	37	2,930	64	93.5	0.89	120.6	2.2	7.3	2.9	16	1,273.9	250
RD	225	M-2	45	2,945	79	93.5	0.88	146	2	7.2	2.6	16	2,215.5	375
RD	250	M-2	55	2,970	95	94.4	0.89	177	2.8	7.5	3.2	16	6,750	485
RD	280	S-2	75	2,980	131	94.5	0.88	241	3.1	8	3	16	9,500	650
RD	280	M-2	90	2,980	152	95	0.9	289	3	8	2.9	16	11,000	700
RD	315	S-2	110	2,970	194	95.5	0.86	354	2.3	6	2.4	13	15,500	820
RD	315	M-2	132	2,970	228	95.5	0.88	425	2.5	6.5	2.8	13	18,000	930

	Type		Power kW	Speed min-1	In (A) 400 Volt	Efficiency %	Power factor cos φ	Torque Nm	Starting torque (MA/MN)	Starting current (IA/IN)	Max. torque (MM/MN)	KR	Torque of inertia (kgmx10 ⁻⁴)	Weight kg
RD	71	A-4	0.25	1,355	0.75	59.5	0.8	1.76	2.15	3.8	2.5	16	5.1	15
RD	71	B-4	0.37	1,350	1.05	63	0.81	2.61	2.25	3.8	2.9	16	6.3	16
RD	80	A-4	0.55	1,410	1.38	72	0.81	3.73	2.3	4.6	2.7	16	9.8	24
RD	80	B-4	0.75	1,400	1.8	76	0.8	5.1	2.4	5	2.6	16	12.5	26
RD	90	S-4	1.1	1,410	2.4	79	0.84	7.5	2.3	5.4	2.4	16	20.4	32
RD	90	L-4	1.5	1,405	3.25	79	0.84	10.2	2.5	5.8	2.6	16	26	35
RD	100	LA-4	2.2	1,405	4.8	79	0.84	15	2.1	5.1	2.2	16	38.8	42.5
RD	100	LB-4	3	1,400	6.4	81	0.84	20.5	2.1	5.3	2.3	16	49.9	46
RD	112	M-4	4	1,430	8.2	85	0.84	26.8	2.2	6.6	2.8	16	101.4	60
RD	132	S-4	5.5	1,435	10.9	84.5	0.86	36.7	2.3	5.5	2.7	16	211.3	84
RD	132	M-4	7.5	1,445	14.8	87	0.85	49.6	2.8	6.5	2.9	16	279.3	93.5
RD	160	M-4	11	1,470	22	87	0.83	71.5	2.7	6.7	2.8	16	541.7	159
RD	160	L-4	15	1,460	29	87.5	0.85	98	2.6	6.3	2.7	16	711.6	178
RD	180	M-4	18.5	1,460	35	92	0.84	121	2.5	6.5	2.3	16	1,129	215
RD	180	L-4	22	1,460	40	92.5	0.86	143.9	2.5	6.4	2.3	16	1,339	236
RD	200	L-4	30	1,460	56	93	0.83	196	2.2	6.2	3	16	2,129.8	250
RD	225	S-4	37	1,465	68	93.5	0.84	241.6	2.2	6.3	2.8	16	3,622.5	310
RD	225	M-4	45	1,465	83	94	0.83	293	2.3	6.2	2.8	16	4,284.5	390
RD	250	M-4	55	1,480	98	94.5	0.86	355	3.1	6.1	2.5	16	8,750	480
RD	280	S-4	75	1,480	135	95	0.86	485	2.4	6.1	2.8	16	18,750	610
RD	280	M-4	90	1,480	158	95	0.87	582	2.8	6.5	2.9	16	22,500	685
RD	315	S-4	110	1,485	193	95.5	0.87	708	2.7	6	2.4	16	35,000	820
RD	315	MA-4	132	1,485	232	95.8	0.87	850	2.5	6.5	2.6	16	38,750	930
RD	315	MB-4	160	1,485	282	96	0.86	1,030	2.7	7	2.6	16	50,000	1,240

ATEX Ex-d(e) Flameproof Electric Motors



Outputs when in continuous use (S1) and at a maximum environmental temperature of 40°C.

Outputs on demand with regard to deviating environmental temperatures, intermittent operation S2, S3, etc., and deviating frequencies.

Ex-II-2G Ex-d(e)-IIc-T4 in accordance with EN 60079-0 and EN 60079-1

	Type		Power	Speed	In (A)	Efficiency	Power factor	Torque	Starting torque	Starting current	Max. torque	KR	Torque of inertia	Weight
			kW	min-1	400 Volt	%	cos φ	Nm	(MA/MN)	(IA/IN)	(MM/MN)		(kgmx10 ⁻⁴)	kg
RD	71	A-6	0.18	930	0.67	60	0.65	1.86	2.1	3.1	2.3	16	8.1	15
RD	71	B-6	0.25	940	0.85	64	0.67	2.56	2.2	3.7	2.5	16	10.1	16
RD	80	A-6	0.37	925	1.1	67	0.72	3.83	2.3	3.6	2.5	16	19.1	25
RD	80	B-6	0.55	915	1.5	72	0.74	5.7	2.35	4.1	2.5	16	23.9	26.5
RD	90	S-6	0.75	915	2.1	70	0.74	7.8	1.8	3.7	2.1	16	32.3	32
RD	90	L-6	1.1	915	3	73	0.73	11.5	2.1	4.1	2.3	16	41.9	35
RD	100	L-6	1.5	930	3.7	76	0.77	15.4	2.2	4.7	2.3	16	65.7	46
RD	112	M-6	2.2	960	5	82	0.78	21.9	2.6	6.1	2.7	16	158	60
RD	132	S-6	3	975	6.6	83.5	0.79	29.4	2.3	6.3	2.5	16	272.2	84
RD	132	MA-6	4	960	8.8	83	0.8	39.9	2.4	6.3	2.9	16	322.9	88
RD	132	MB-6	5.5	955	11.8	83.5	0.81	55.1	2.3	6.1	2.9	16	383.8	95
RD	160	M-6	7.5	970	15.8	86	0.8	74.2	2.7	6.7	2.4	16	812.1	161
RD	160	L-6	11	965	23.5	88.5	0.77	109	2.2	6	2.3	16	1,091.6	182
RD	180	L-6	15	965	31	89.5	0.78	148	1.9	5.2	2.3	16	2,270	236
RD	200	LA-6	18.5	965	36	91	0.81	183	1.9	6	2.4	16	2,436.9	240
RD	200	LB-6	22	965	43	91.5	0.81	218.6	1.9	6	2.4	16	2,788.8	250
RD	225	M-6	30	975	56	92.5	0.83	293	1.8	5.8	2.5	16	6,611.7	390
RD	250	M-6	37	985	69	93.5	0.83	359	2.8	6	2.6	16	11,250	480
RD	280	S-6	45	985	82	94.5	0.84	437	2.5	6.3	2.7	16	23,000	610
RD	280	M-6	55	985	101	94.5	0.84	534	2.4	6	2.8	16	26,250	685
RD	315	S-6	75	980	140	95	0.82	732	2.5	5.9	2.8	16	46,250	820
RD	315	MA-6	90	985	163	95.5	0.84	874	2.1	5.1	2.9	16	52,500	930

	Type		Power	Speed	In (A)	Efficiency	Power factor	Torque	Starting torque	Starting current	Max. torque	KR	Torque of inertia	Weight
			kW	min-1	400 Volt	%	cos φ	Nm	(MA/MN)	(IA/IN)	(MM/MN)		(kgmx10 ⁻⁴)	kg
RD	71	A-8	0.09	680	0.67	38	0.51	1.26	2	2	2.1	16	8.1	15
RD	71	B-8	0.12	655	0.54	45	0.71	1.75	1.8	2.4	2.1	16	10.1	16
RD	80	A-8	0.18	680	0.66	61	0.65	2.53	2.1	2.9	2.2	16	19.1	25
RD	80	B-8	0.25	680	0.92	58	0.68	3.52	2.1	3.1	2.3	16	23.9	26.5
RD	90	S-8	0.37	685	1.25	66	0.65	5.2	1.7	3	2	16	32.3	32
RD	90	L-8	0.55	685	1.75	69	0.66	7.7	1.75	3.1	2.1	16	41.9	35
RD	100	LA-8	0.75	690	2.3	69	0.69	10.4	1.8	3.5	2.1	16	65.7	42.5
RD	100	LB-8	1.1	695	3.25	70	0.7	15	1.9	3.8	2.2	16	85.7	46
RD	112	M-8	1.5	710	4.15	78	0.67	20.2	2	4.3	2.5	16	158	60
RD	132	S-8	2.2	710	5.5	79	0.74	29.6	1.9	4.3	2.2	16	260.6	79
RD	132	M-8	3	710	7.2	80	0.76	40.4	2.1	4.8	2.3	16	344.6	85
RD	160	MA-8	4	720	10	82.6	0.71	53.1	1.8	4.8	2.3	16	688	146
RD	160	MB-8	5.5	715	13.4	84	0.71	73.6	1.8	4.8	2.1	16	893.9	160
RD	160	L-8	7.5	725	16.7	86.5	0.75	98.8	2.3	5.8	2.1	16	1,202.7	182
RD	180	L-8	11	715	25	86.7	0.74	147	1.8	4.2	2.5	16	2,270	236
RD	200	L-8	15	720	29	91	0.82	196	2.1	4.5	2.5	16	3,782.7	250
RD	225	S-8	18.5	710	37	91	0.79	249	2.1	4.6	2.6	16	5,700.8	310
RD	225	M-8	22	715	45	91.5	0.77	294	2.1	4.6	2.6	16	6,780.6	390
RD	250	M-8	30	730	59	92.8	0.79	398	1.7	5.4	2.4	16	11,750	480
RD	280	S-8	37	730	74	93	0.78	485	1.9	6	2.3	16	23,000	610
RD	280	M-8	45	735	90	93.5	0.78	586	1.9	6.4	2.7	16	26,250	685
RD	315	S-8	55	735	104	94.5	0.81	716	2.2	6.2	2.3	16	46,250	820
RD	315	M-8	75	740	140	94.5	0.82	969	1.8	6.3	2.1	16	52,500	930



Outputs when in continuous use (S1) and at a maximum environmental temperature of 40°C.

Outputs on demand with regard to deviating environmental temperatures, intermittent operation S2, S3, etc., and deviating frequencies.

Ex-II-2G Ex-e-II-T3 in accordance with EN 60079-0 and EN 60079-7

Housing size IEC type	Power kW	Rotational speed min ⁻¹	Nominal current at 400 V A	tE time sec	Power factor cos φ	Efficiency %	Starting current Ia/In	Starting torque Ma/Mn	Kip torque Mk/Mn	Nominal torque Nm	Mass inertia J kgmx10 ⁻⁴	Mass kg	Certificaat no. goedgekeurd door KEMA
2-pole synchronous rotational speed 3,000 min⁻¹													
RE63M02K	0.18	2,810	0.55	27	0.74	70	4.4	2.3	2.5	0.6	1.8	4	00ATEX2081
RE63M02	0.25	2,800	0.71	16	0.82	68	4.4	2.0	3.0	0.8	2.3	5	00ATEX2081
RE71M02K	0.37	2,825	0.93	25	0.80	72.5	5.6	3.0	3.0	1.3	3.5	6	00ATEX2082
RE71M02K	0.55	2,785	1.40	13	0.79	73	5.2	3.2	2.8	1.9	4.5	7	00ATEX2082
RE80M02K	0.75	2,845	1.81	11	0.85	74	6.2	2.5	2.7	2.5	8.5	9	00ATEX2083
RE80M02K	1.1	2,855	2.50	10	0.85	76	6.4	2.7	3.0	3.7	11	11	00ATEX2083
RE90S02	1.3	2,850	2.90	11	0.88	81	6.2	2.6	2.8	4.4	20	14	00ATEX2084
RE90L02	1.85	2,860	3.95	8	0.88	83	7.2	2.8	2.8	6.2	15	16	00ATEX2084
RE100L02	2.5	2,865	5.30	8	0.86	82.5	7.4	2.6	2.8	8.3	38	30	00ATEX2085
RE112M02	3.3	2,875	6.7	9	0.90	84	6.6	2.1	2.6	11	55	40	00ATEX2086
RE132S02	4.6	2,895	9.2	13	0.90	83.5	6.8	1.9	2.5	15	160	55	00ATEX2087
RE132S02	5.5	2,920	10.6	13	0.92	86	7.7	2.2	3.5	18	210	58	00ATEX2087
RE132S02	6.5	2,900	12.5	7	0.93	85.5	6.6	1.9	3.2	22	210	62	00ATEX2087
RE160M02	7.5	2,945	14.3	18	0.90	86	7.6	2.2	3.1	24	340	96	00ATEX2088
RE160M02	10	2,940	18.6	12	0.92	88.5	7.6	2.1	2.9	32	400	110	00ATEX2088
RE160L02	12.5	2,940	23.0	9	0.93	90.5	7.6	2.2	3.0	41	520	117	00ATEX2088
4-pole synchronous rotational speed 1,500 min⁻¹													
RE63M04K	0.12	1,375	0.52	30	0.66	55	2.6	2.1	2.3	0.8	3	4	00ATEX2081
RE63M04	0.18	1,330	0.62	25	0.75	56	2.7	1.8	1.8	1.3	4	5	00ATEX2081
RE71M04K	0.25	1,310	0.80	40	0.77	59	3.1	1.8	1.7	1.8	6	6	00ATEX2082
RE71M04	0.37	1,355	1.11	29	0.79	66.5	3.7	1.8	1.8	2.6	8	7	00ATEX2082
RE80M04K	0.55	1,390	1.57	21	0.73	69	4.6	3.0	2.5	3.8	15	9	00ATEX2083
RE80M04K	0.75	1,395	2.05	16	0.75	71	4.8	2.5	2.9	5.1	18	10	00ATEX2083
RE90S04	1	1,420	2.50	14	0.79	76.5	5.4	2.8	3.1	6.7	28	13	00ATEX2084
RE90L04	1.35	1,415	3.10	13	0.82	78.5	5.9	2.6	3.1	9.1	35	16	00ATEX2084
RE100L04K	2	1,420	4.64	11	0.79	79.5	6.4	2.5	2.7	13	48	31	00ATEX2085
RE100L04	2.5	1,415	5.50	10	0.84	81.5	6.4	2.6	2.7	16	58	33	00ATEX2085
RE112M04	3.6	1,435	7.50	9	0.83	85.5	7.2	2.6	2.9	24	110	42	00ATEX2086
RE132S04	5	1,455	10.4	9	0.83	87	6.6	2.5	3.3	33	210	57	00ATEX2087
RE132M04	6.8	1,460	14.1	9	0.82	87	7.7	2.7	3.8	45	270	78	00ATEX2087
RE160M04	10	1,455	19.7	10	0.87	89.5	6.5	2.1	2.7	66	520	115	00ATEX2088
RE160L04	13.5	1,465	27.0	9	0.84	90.5	6.9	2.8	3.1	89	570	134	00ATEX2088
6-pole synchronous rotational speed 1,000 min⁻¹													
RE71M06	0.25	851	0.81	70	0.72	64	3.0	1.9	1.9	2.1	9	7	00ATEX2082
RE80M06K	0.37	920	1.14	55	0.70	68	3.6	2.3	2.4	3.8	15	9	00ATEX2083
RE80M06	0.55	930	1.75	27	0.67	61.5	4.0	2.4	2.4	5.6	25	10	00ATEX2083
RE90S06	0.65	915	1.80	30	0.75	70	3.9	2.0	2.3	6.8	28	13	00ATEX2084
RE90L06	0.95	910	2.60	19	0.75	71	4.1	2.3	2.4	10	38	16	00ATEX2084
RE100L06	1.3	935	3.40	26	0.73	75.3	4.8	2.4	2.5	13	63	31	00ATEX2085
RE112M06	1.9	940	4.70	16	0.76	76.5	5	2.3	2.3	19	110	40	00ATEX2086
RE132S06	2.6	945	6.50	18	0.76	78.5	4.4	2	2.2	26	150	58	00ATEX2087
RE132M06	3.5	955	9.00	13	0.72	81	5.1	2.3	2.8	35	190	60	00ATEX2087
RE132M06	4.8	950	11.4	11	0.76	83	5.6	2.5	2.9	48	250	68	00ATEX2087
RE160M06	6.6	960	14.9	9	0.75	86.5	6.4	2	2.5	65	410	103	00ATEX2088
RE160L06	9.7	965	21.0	8	0.76	88.5	7.7	2.8	3.5	26	550	118	00ATEX2088

ATEX Ex-nA Non-sparking Electric Motors



Outputs when in continuous use (S1) and at a maximum environmental temperature of 40°C.

Outputs on demand with regard to deviating environmental temperatures, intermittent operation S2, S3, etc., and deviating frequencies.

Ex-II-3G Ex-nA-II-T3 in accordance with EN 60079-0 and EN 60079-15

Housing size IEC type	Power kW	Rotational speed min ⁻¹	Nominal current at 400 V A	Power factor cos φ -	Efficiency %	Starting current Ia/In -	Starting torque Ma/Mn -	Saddle torque Mz/Mn -	Nominal torque Nm	Mass inertia J kgm ² 10 ⁻⁴	Mass kg
2-pole synchronous rotational speed 3,000 min⁻¹											
RN63-2K	0.18	2,820	0.51	0.72	62	3.8	2.2	2.1	0.6	1.8	4
RN63-2	0.25	2,830	0.69	0.80	65	4.1	1.9	1.9	0.8	2.3	5
RN63M02V	0.45	2,720	1.09	0.88	67	4.2	2.0	1.8	0.2	2.8	5
RN71-2K	0.37	2,740	1.05	0.82	62	3.7	2.2	2.1	1.3	3.5	6
RN71-2	0.55	2,800	1.45	0.81	67	4.7	2.6	2.6	1.9	4.3	7
RN80M02V	1.75	2,835	4.10	0.78	78.5	7.0	4.2	4.1	5.9	14	11
RN80-2K	0.75	2,855	1.80	0.85	71	5.8	2.3	1.6	2.5	8.5	8
RN80-2	1.1	2,850	2.40	0.86	77.5	6.3	2.4	1.8	3.7	11	10
RN80M02V	1.75	2,835	4.10	0.78	78.5	7.0	4.2	4.1	5.9	14	11
RN90S-2	1.5	2,855	3.35	0.86	76.5	5.7	2.3	2.3	5.0	18	11
RN90L-2	2.2	2,880	4.60	0.85	81	7.0	2.8	2.5	7.3	22	14
RN90L02V	3.8	2,780	8.0	0.84	81	6.0	3.1	3.0	13	25	14
RN100L-2	3	2,880	6.3	0.79	82	7.2	2.9	2.8	10	38	29
RN100L02V	4.6	2,880	9.8	0.81	84.5	8.0	3.7	3.4	15	44	34
RN112M-2	4	2,890	8.0	0.86	83	7.2	2.7	2.1	13	70	45
RN112L02V	5.5	2,905	10.7	0.86	86.5	6.1	2.7	2.2	18	77	48
RN132S-2K	5.5	2,895	10.8	0.90	81.5	6.1	1.8	1.8	18	120	52
RN132S-2	7.5	2,905	14.2	0.92	82.5	7.3	2.5	2.0	25	140	58
RN132L02V	11	2,900	20.8	0.90	84.5	7.6	2.7	2.2	36	210	70
RN160M-2K	11	2,910	22.2	0.88	84	5.6	1.8	1.5	36	340	96
RN160M-2	15	2,930	26.9	0.91	89	6.7	1.9	1.6	49	430	100
RN160L-2	18.5	2,935	32.8	0.90	90	7.5	2.1	1.8	60	520	111
RN160L02V	24.5	2,920	44.1	0.90	89	7.5	2.6	1.9	80	650	90
RN180M-2	22	2,945	40.8	0.86	91.5	6.4	2.5	2.3	71	680	145
RN200Lk-2	30	2,950	54	0.88	92	6.5	2.6	1.8	97	1,290	205
RN200L-2	37	2,950	66	0.89	93	7.2	2.5	2.2	120	1,530	225
RN225M-2	45	2,960	79	0.87	93.5	6.7	2.4	2.0	145	2,170	285
RN250M-2	55	2,960	95	0.88	94	6.7	2.1	1.8	177	4,030	375
RN280S-2	75	2,975	130	0.88	95	7.5	2.5	2.0	241	7,150	500
RN280M-2	90	2,975	154	0.89	95	7.2	2.6	2.0	289	8,320	540
RN315S-2	110	2,982	190	0.88	94.5	7.2	2.4	1.9	352	12,000	720
RN315M-2	132	2,982	225	0.90	95	6.9	2.4	1.8	423	13,900	775
RN315L-2	160	2,982	267	0.91	95.5	7.0	2.4	1.9	512	16,200	900
RN315L-2	200	2,982	329	0.92	96	6.7	2.3	1.8	641	21,000	1,015
2-pole synchronous rotational speed 1,500 min⁻¹											
RN63-4K	0.12	1,380	0.45	0.70	56	2.8	2.1	2.0	0.8	3	5
RN63-4	0.18	1,345	0.60	0.77	57	2.8	1.8	1.7	1.3	4	5
RN63M04V	0.29	1,320	0.95	0.75	58	2.9	2.1	2.1	2.1	5	5
RN71-4K	0.25	1,315	0.83	0.76	57	2.8	1.7	1.7	1.8	6	5
RN71-4	0.37	1,350	1.10	0.78	62.5	3.3	1.9	1.7	2.6	7	6
RN71M04V	0.6	1,350	1.60	0.78	70	4.0	2.4	2.1	4.2	9	7
RN80-4K	0.55	1,380	1.50	0.82	65.5	3.8	2.0	2.0	3.8	10	7
RN80-4	0.75	1,380	2.03	0.79	73	4.0	2.2	2.0	5.2	18	9
RN80M04V	1.25	1,382	3.00	0.81	75	4.7	2.8	2.5	8.6	25	12
RN90S-4	1.1	1,415	2.60	0.79	77.5	5.2	2.5	2.2	7.4	28	11
RN90L-4	1.5	1,415	3.55	0.78	78.5	5.4	2.6	2.1	10	44	14
RN90L04V	2.5	1,360	5.90	0.80	76	4.5	2.8	2.8	18	43	17.5
RN100L-4K	2.2	1,420	4.90	0.83	78	5.5	2.4	2.2	15	48	32
RN100L-4	3	1,405	6.8	0.79	80.5	5.4	2.8	2.6	20	58	34
RN100L04V	3.8	1,395	8.4	0.81	80	5.4	2.9	2.8	26	70	39
RN112M-4	4	1,430	8.7	0.80	83	6.3	2.7	2.4	27	134	42
RN112L04V	5.5	14,354	12.6	0.78	51.5	6.5	3.3	2.8	37	140	48
RN132S-4	5.5	1,450	12.1	0.78	84	6.3	2.5	2.3	36	273	54
RN132M-4	7.5	1,450	15.8	0.81	84.5	7.1	2.8	2.6	49	300	61
RN132L04V	10	1,440	21.0	0.80	86	7.0	3.3	2.7	66	300	74
RN160M-4	11	1,455	22.0	0.83	87	6.4	2.5	2.0	72	400	100
RN160L-4	15	1,455	29.8	0.82	88.5	6.9	2.6	2.1	98	550	120
RN160L04V	22	1,452	44.0	0.82	88	7.1	2.3	1.7	145	570	132
RN180M04A3	18.5	1,465	35.0	0.84	90.5	6.7	2.4	1.9	121	990	140
RN180L04A6	22	1,465	41.5	0.84	91	6.9	2.5	2.2	143	1,170	155
RN200L04A7	30	1,465	56	0.85	91.5	6.7	2.5	2.3	196	1,910	205
RN225S04A0	37	1,475	68	0.85	92.5	6.7	2.5	2.1	240	3,740	265
RN225M04A3	45	1,475	82	0.86	93	7.2	2.7	2.4	292	4,470	300
RN250M04A3	55	1,480	100	0.85	93.5	6.1	2.4	2.0	355	6,880	387
RN280S04A0	75	1,485	136	0.85	94.5	7.1	2.5	1.9	483	11,900	535
RN280M04A3	90	1,485	160	0.86	94.5	7.4	2.5	2.2	579	13,900	580
RN315S04A0	110	1,488	198	0.85	94.5	6.4	2.5	2.0	706	19,400	730
RN315M04A3	132	1,488	235	0.85	95.2	6.8	2.7	2.2	847	23,100	810
RN315L04A6	160	1,486	280	0.86	96	6.8	2.7	2.2	1,028	28,800	955
RN315L04A7	200	1,486	340	0.88	96	6.5	2.6	1.9	1,285	34,600	1,060



Outputs when in continuous use (S1) and at a maximum environmental temperature of 40°C.

Outputs on demand with regard to deviating environmental temperatures, intermittent operation S2, S3, etc., and deviating frequencies.

Ex-II-3G Ex-nA-II-T3 in accordance with EN 60079-0 and EN 60079-15

Housing size IEC type	Power kW	Rotational speed min ⁻¹	Nominal current at 400 V A	Power factor cos φ	Efficiency %	Starting current Ia/In	Starting torque Ma/Mn	Saddle torque Mz/Mn	Nominal torque Nm	Mass inertia J kgm ² ·10 ⁻⁴	Mass kg
6-pole synchronous rotational speed 1,000 min⁻¹											
5RN63M06V	0.12	890	0.6	0.61	45	2.1	2.2	1.8	1.29	5	5
RN71-6K	0.18	850	0.65	0.75	54.5	2.5	1.9	1.9	2.1	5	7
RN71-6	0.25	860	0.81	0.76	59	2.7	2.0	2.0	2.9	9	7
RN80-6K	0.37	920	1.25	0.74	59.5	3.1	1.8	1.7	3.9	15	7
RN80-6	0.55	910	1.76	0.74	61	3.0	1.8	1.8	5.9	18	9
RN90S-6	0.75	915	2.26	0.73	67.5	3.1	1.9	1.8	7.9	28	11
RN90L-6	1.1	915	3.09	0.74	69.5	3.5	2.2	2.0	12	35	15
RN90L06V	1.5	850	4.10	0.79	67	3.6	2.4	2.0	17	44	19
RN100L-6	1.5	920	4.00	0.75	73.5	3.8	2.2	2.1	16	63	32
RN112M-6	2.2	939	5.6	0.73	77.5	4.8	2.2	2.2	22	150	49
RN112L06V	3	930	7.40	0.76	77	4.6	2.3	1.9	31	150	42
RN112L06V	3	930	7.40	0.76	77	4.6	2.3	1.9	31	150	42
RN132S-6	3	949	7.2	0.77	78	4.4	1.8	1.5	30	150	49
RN132M-6K	4	950	9.9	0.73	79	5.0	2.4	2.2	40	190	56
RN132M-6	5.5	950	13.6	0.71	82	5.3	2.4	2.2	55	256	64
RN160M-6	7.5	955	17.5	0.73	84	4.4	1.8	1.6	75	410	100
RN160L-6	11	955	24.5	0.74	87.5	4.7	1.9	1.7	110	490	121
RN200Lk-6	18.5	975	36.5	0.81	90	5.6	2.5	2.0	181	2,380	195
RN200L-6	22	975	43.5	0.81	90.5	5.7	2.6	2.1	216	2,870	205
RN225M-6	30	978	58	0.83	92	5.6	2.7	2.4	293	4,920	280
RN250M-6	37	980	71	0.83	92.5	6.0	2.7	2.2	360	7,620	370
RN280S-6	45	985	83	0.85	92.5	6.1	2.4	2.1	436	11,200	475
RN280M-6	55	985	100	0.86	93	6.3	2.5	2.2	533	13,700	510
RN315S-6	75	988	138	0.84	93.5	6.5	2.5	2.2	725	21,000	685
RN315M-6	90	988	164	0.84	94	6.8	2.6	2.4	870	25,000	750
RN315L-6A6	110	988	196	0.86	94.5	6.8	2.5	2.3	1,063	32,000	890
RN315L-6A7	132	988	235	0.86	95	7.3	3.1	2.5	1,276	40,200	980
8-pole synchronous rotational speed 750 min⁻¹											
RN63-8	0.04	640	0.29	0.65	31	1.6	1.77	1.75	0.6	7	5
RN71-8K	0.09	630	0.38	0.72	50	2.1	1.7	1.8	1.4	8	7
RN71-8	0.12	645	0.54	0.64	51.5	2.3	2.2	2.2	1.8	8	7
RN80-8K	0.18	675	0.78	0.66	51	2.3	1.6	1.6	2.6	14	8
RN80-8	0.25	680	1.14	0.61	53.5	2.3	1.9	1.7	3.5	18	10
RN90S-8	0.37	675	1.13	0.75	63	2.7	1.5	1.5	5.2	25	10
RN90L-8	0.55	675	1.60	0.74	66.5	2.9	1.6	1.5	8	35	11
RN90L08V	0.75	670	2.20	0.72	70	3.0	2.0	2.0	11	48	11
RN100L-8	0.75	675	2.10	0.77	67.5	3.0	1.6	1.5	11	53	28
RN100L-8	1.1	670	2.90	0.75	72.5	3.1	1.7	1.7	16	70	30
RN112M-8	1.5	695	4.20	0.73	71.5	3.8	1.8	1.6	21	130	33
RN112M08V	2.2	695	6.2	0.71	72.5	4.0	2.2	1.9	30	190	42
RN132S-8	2.2	695	6.3	0.70	72	3.7	2.0	1.8	30	140	52
RN132M-8	3	690	8.5	0.69	74	3.7	2.1	2.0	42	190	57
RN132M08V	4	690	11.3	0.68	74.2	4.0	2.2	2.0	55	250	67
RN160M-8K	4	710	10.5	0.70	77.5	4.3	1.9	1.7	54	350	87
RN160M-8	5.5	705	13.8	0.72	79.5	4.4	1.9	1.5	75	430	97
RN160L-8	7.5	711	18.5	0.71	82.5	4.9	2.4	1.6	101	1,370	125
RN180L08B6	11	725	25.0	0.73	87.5	4.2	1.7	1.5	145	1,690	150
RN200Lk08	15	725	32.5	0.76	88	4.9	2.2	1.9	198	2,900	205
RN225S08	18.5	730	38.5	0.78	89.5	5.5	2.3	2.0	242	4,820	270
RN225M08	22	730	45.0	0.79	90	5.5	2.3	2.1	288	5,510	290
RN250M08	30	730	58	0.81	91.5	5.5	2.3	2.1	392	8,370	385
RN280S08	37	735	72	0.81	92	5.0	2.2	1.8	481	11,100	475
RN280M08	45	735	87	0.81	92.5	5.1	2.2	2.0	585	13,500	515
RN315S08	55	740	106	0.81	93	5.8	2.2	1.9	710	20,800	680
RN315M08	75	738	140	0.83	93.5	5.7	2.2	1.9	971	24,800	745
RN315L08B6	90	738	168	0.83	93.5	5.8	2.2	1.9	1,165	31,400	865
RN315L08B7	110	738	205	0.83	94	6.1	2.4	2.0	1,423	39,500	1,020

Non-sparking structure



Outputs when in continuous use (S1) and at a maximum environmental temperature of 40°C.

Outputs on demand with regard to deviating environmental temperatures, intermittent operation S2, S3, etc., and deviating frequencies.

Ex-II-3G Ex-nA-II-T3 in accordance with EN 60079-0 and EN 60079-15

Housing size IEC type	Power kW	Rotational speed min ⁻¹	Nominal current at 400 V A	Power factor cos φ -	Efficiency %	Starting current Ia/In -	Starting torque Ma/Mn -	Saddle torque Mz/Mn -	Nominal torque Nm	Mass inertia J kgmx10 ⁻⁴	Mass kg
2-polig synchroon toerental 3000 min⁻¹											
RN63M02V	0.45	2720	1.15	0.84	68	4.2	2.2	1.8	1.6	2.6	5
RN71M02V	0.94	2690	2.21	0.84	73.5	4.8	3.1	2.5	3.3	4.5	7
RN80M02V	1.75	2840	4.10	0.82	77	7.0	4.2	4.1	5.9	13	14
RN90L02V	3.8	2810	8.0	0.85	82	6.0	3.1	3.0	13	22	20
RN100L02V	4.6	2880	9.8	0.81	84	8.0	3.7	3.4	15	44	34
RN112M02V	5.5	2905	10.7	0.87	86.5	7.5	2.7	2.2	18	77	48
RN132M02V	11	2900	20.8	0.91	84.5	7.6	2.7	2.2	36	240	73
RN160L02V	24.5	2920	44.1	0.90	89	7.5	2.6	1.9	80	650	134
RN180L02A8	30	2950	54	0.86	93	7.5	2.4	2.2	97	860	175
RN200L02A8	45	2955	78	0.89	93.5	6.9	2.5	2.1	145	1,820	255
RN225M02A8	55	2960	94	0.89	95	7.3	2.6	2.3	177	2,660	335
RN250M02A8	75	2970	130	0.88	94.5	7.1	2.4	2.0	241	4,800	420
RN280M02B8	110	2975	184	0.90	95.5	7.0	2.5	2.0	353	10,000	630
RN315L02B8	250	2982	410	0.92	96	6.7	2.4	1.9	801	24,600	1,230
RN315L02A9	315	2980	530	0.89	96.5	9.2	3.4	3.0	1,007	28,800	1,350
4-polig synchroon toerental 1500 min⁻¹											
RN63M04V	0.29	1330	0.80	0.71	60	2.9	2.3	2.1	2.1	4.5	5
RN71M04V	0.6	1350	1.60	0.79	70	4.0	2.4	2.1	4.2	9.5	7
RN80M04V	1.25	1380	3.00	0.81	76	4.7	2.8	2.5	8.6	24	14
RN90L04V	2.5	1380	5.90	0.80	76	4.5	2.8	2.7	18	40	17.5
RN100L04V	3.8	1395	8.4	0.81	80	5.8	2.9	2.4	26	62	34
RN112L04V	5.5	1440	12.7	0.78	81	6.5	3.3	2.8	37	140	48
RN132L04V	10	1440	21.0	0.81	85	7.0	3.3	2.7	66	300	74
RN160L04V	22	1450	44.0	0.82	88	7.1	2.3	1.7	145	720	132
RN180L04A8	30	1465	59	0.80	92	6.3	2.6	2.2	196	1,440	180
RN200L04A8	37	1465	70	0.83	92.5	6.9	2.6	2.1	241	2,340	230
RN225M04A8	55	1475	99	0.86	93.5	6.8	2.5	2.1	356	4,860	330
RN250M04A8	75	1485	136	0.85	94.5	7.7	2.5	2.2	483	8,560	460
RN280M04B8	110	1490	198	0.84	95.5	7.9	2.8	2.7	707	17,100	680
RN315L04B8	250	1488	430	0.87	96	7.7	3.1	2.4	1,604	42,200	1,290
RN315L04A9	315	1490	550	0.86	96	7.7	3.4	2.4	2,020	52,000	1,520
6-polig synchroon toerental 1000 min⁻¹											
5RN63M06V	0.12	890	0.64	0.61	45	2.1	2.2	1.8	1.29	4.5	5
RN90L06V	1.5	850	4.11	0.81	67	3.6	2.4	2.0	17	44	19
RN112M06V	3	930	7.41	0.76	78	4.6	2.3	1.9	31	150	42
RN180L06A8	18.5	970	37.5	0.80	90	4.9	2.2	2.0	182	2,030	175
RN200L06A8	30	975	60	0.80	91	5.8	2.6	2.3	294	3,620	245
RN225M06A8	37	980	71	0.83	92.5	5.9	2.5	2.3	361	6,240	325
RN250M06A8	45	982	85	0.83	93.5	6.3	2.7	2.2	438	9,340	405
RN280M06A8	75	984	136	0.86	94	6.8	3.0	2.5	728	20,000	660
RN315L-6A8	160	988	285	0.86	95	7.5	3	2.51	1,547	47,100	1,180
RN315L-6A9	200	990	360	0.84	95.5	7.5	2.9	2.33	1,929	57,200	1,400
8-polig synchroon toerental 750 min⁻¹											
RN90L08V	0.75	670	2.21	0.72	70	3.0	2.0	2.0	11	51	16
RN112M08V	2.2	695	6.2	0.71	73	3.9	2.2	1.9	30	190	42
RN132M08V	4	690	11.5	0.68	74	3.9	2.2	2.0	55	250	74
RN180L08B8	15	720	34.0	0.73	88	4.5	2.0	1.8	199	2,060	165
RN200L08B8	18.5	725	39.5	0.78	88.5	5.5	2.5	2.0	244	3,670	230
RN225M08B8	30	730	61	0.79	90.5	6.0	2.5	2.3	392	7,300	345
RN250M08B8	37	731	72	0.82	92	5.9	2.3	2.2	483	10,610	405
RN280M08B8	55	736	106	0.81	93	5.9	2.4	2.1	714	16,300	560
RN315L08B8	132	738	245	0.83	94.5	6.5	2.5	2.1	1,708	45,200	1,100
RN315L08B9	160	738	290	0.84	94.5	6.5	2.6	2.2	2,070	48,000	1,380

61



Category and Area Classification for Dust Atmospheres (dust)

- Our 3D range of motors can be derived from our standard range (certain modifications must be performed)
- Our 2D range of motors in flameproof enclosure are also available at short lead times (Ex d).

Two groups are referred to in the ATEX 95 directive: I and II. Both groups are subdivided into categories. These categories indicate whether a device or protection system can be deployed in a possibly explosive atmosphere with gas, mist or fumes (G) or with dust (D).

- ATEX 95 group I: = mining industry
 group II: = other locations
- Category 1D Zone 20
 - Category 2D Zone 21
 - Category 3D Zone 22

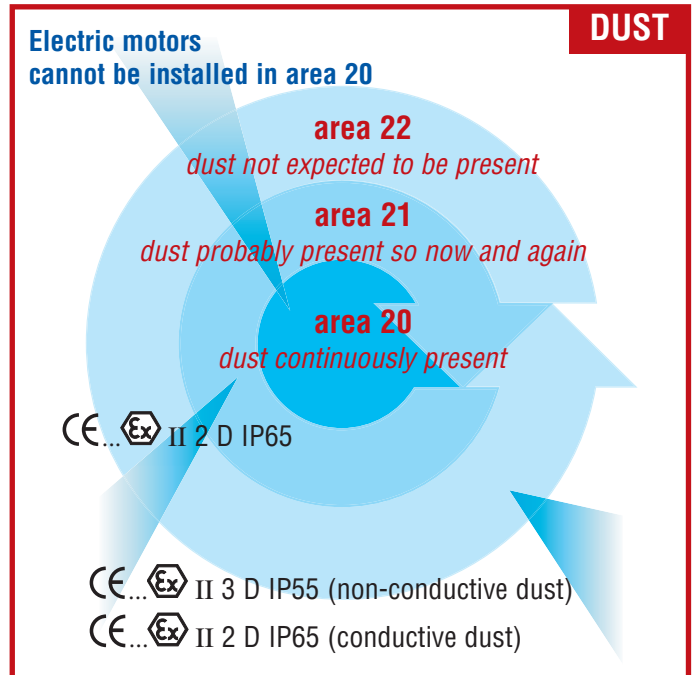

Coding for Electric Motors in Dust Explosive Area

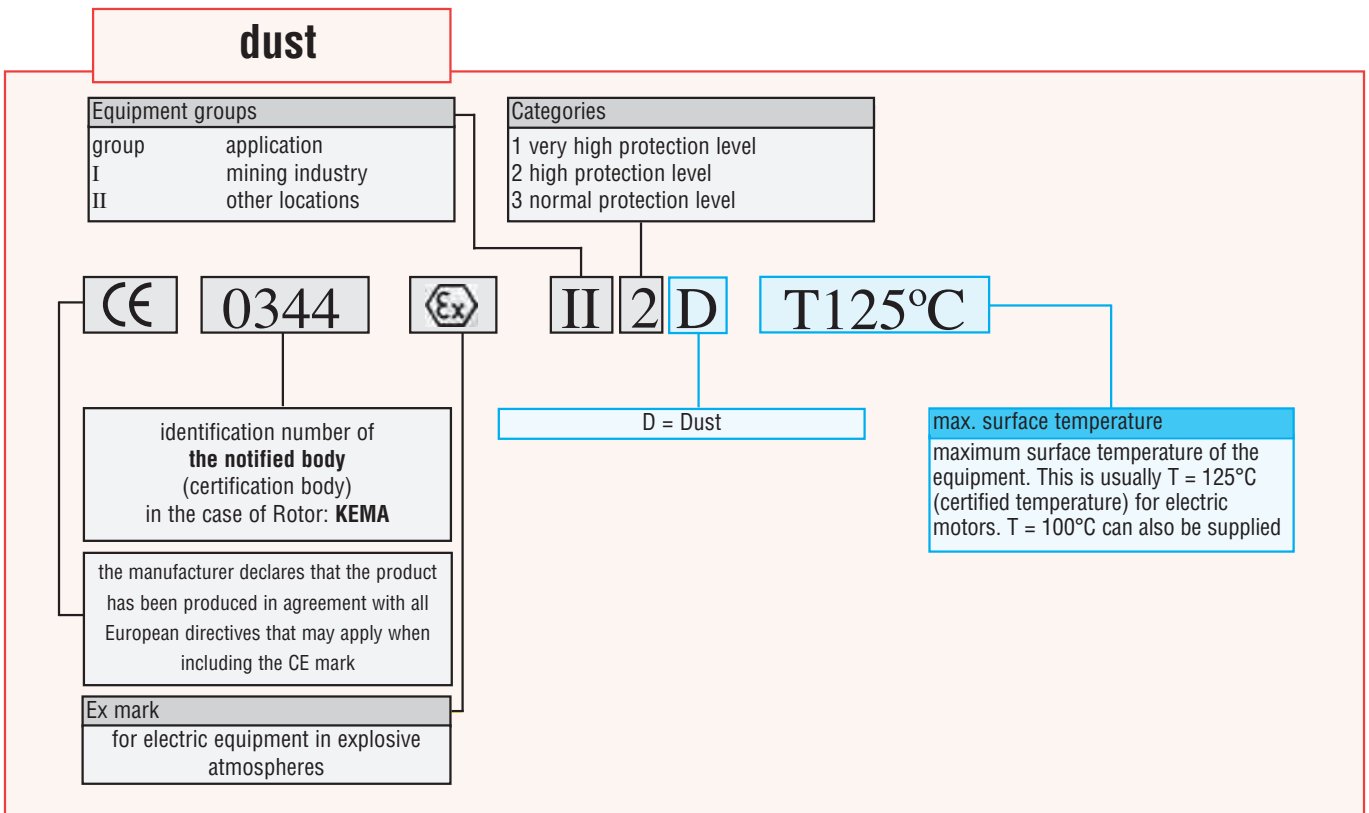

Electric data of these electric motors are the same as the standard line of the RN series. Electric motors can be ordered with contract variations
 Ex II 2D through BG 160
 Ex II 3D through BG 315

Other constructions sizes on request

Motor Execution Options

Rotor nI® electric motors: IP55. are standard equipped with pre-loaded, enclosed bearings fixed at NDE, RAL 7030. tropical insulation 96% RH and low noise performance.

Rotor electric motors are also available as special models. Provided below is a list of motor execution options. Customer-specific modifications are also possible. If required, please get in touch with your contact person.

Contract variation options	Page
Extra tropical insulation 98% RH	page 28
IPW55 additional shaft seal DE	page 28
IPW55 additional shaft seal DE & NDE 98% RH	page 28
IP56 98% RH	page 28
Oil-tight flange	page 27
Standstill heating 230 V	page 31
Terminal box—on right hand side	page 43
Terminal box—on left hand side	page 43
Force ventilation unit, IC416	page 32
TEAO, IC418	page 32
TENV, IC410 (short-term operation)	page 32
Hydraulic model H.V.O., IC08	page 32
PT100 temp. measuring element (1 pc.)	page 30
PTC tripping temp. monitoring elements	page 31
PTC alarm temp. monitoring elements	page 70
Bi-metal tripping temp. monitoring elements	page 30
Bi-metal alarm temp. monitoring elements	page 30
Strengthened pre-loaded bearing	page 38
SPM vibration monitoring nipples	page 38
PT100 bearing temp. measuring element	page 30
Balancing of class “B”, no key	page 38
Insulated bearing	page 34, 35
C3 paint finish (stock colour) in accordance with ISO 12944	page 73
C5 paint finish (stock colour)	page 73
CSA inspection LR 39731/206768 metric swivel sockets	
Marine execution	page 52
Factory inspection certificate EN 10204—2.2	page 52
Inspection report (no load test) EN 10204—3.1	page 52
Inspection report (load test) EN 10204—3.1	page 52
Classified inspection report EN 10204—3.2	page 52

Pole-changing Motors Electrical Data

On this and the following pages, you will find an overview of the range of Pole-changing electric motors we provide. Information about these electric motors can be found on page 34. To make an informed decision about your order, please contact one of our staff members to learn more about the options available.

Outputs when in continuous use (S1) and at a maximum environmental temperature of 40°C.

Outputs on demand with regard to deviating environmental temperatures, intermittent operation S2, S3, etc., and deviating frequencies.

Housing size IEC type	Power kW	Rotational speed min ⁻¹	Nominal current at 400 V A	Power factor cos φ -	Efficiency %	Starting current Ia/In -	Starting torque Ma/Mn -	Saddle torque Mz/Mn -	Stall torque Mk/Mn -	Nominal torque Nm	Mass inertia J kgmx10 ⁻⁴	Mass kg
<i>4/2-pole synchronous rotational speed 1,500/3,000 min⁻¹ Δ/YY for constant torque application</i>												
RN63M21	0.15	1,330	0.68	0.71	45	3.0	2.0	1.7	2.0	1.1	4.5	4.5
	0.2	2,700	0.70	0.73	57	3.3	2.0	1.7	2.0	0.7		
RN71M21K	0.21	1,365	0.71	0.72	60	2.9	1.8	1.6	1.9	1.5	5.2	5.5
	0.28	2,740	0.94	0.77	56	3.0	2.1	1.9	2.1	1.0		
RN71M21	0.3	1,385	0.89	0.73	67	3.8	2.3	2.0	2.3	2.0	7.7	6.5
	0.43	2,795	1.21	0.80	65	3.9	2.7	2.3	2.6	1.5		
RN80M21K	0.48	1,390	1.25	0.81	66	3.9	1.8	1.7	2.0	3.4	14	9
	0.6	2,810	1.60	0.85	64	4.0	1.7	1.7	2.0	2.1		
RN80M21	0.7	1,390	1.75	0.84	69	4.3	2.2	2.1	2.1	4.9	17	10
	0.85	2,810	2.2	0.86	68	4.3	2.2	2.1	2.1	2.9		
RN90S21	1.1	1,400	2.6	0.80	76	4.4	2.1	2.1	2.6	7.5	28	14
	1.4	2,840	3.3	0.83	74	4.9	2.2	2.0	2.7	4.7		
RN90L21	1.5	1,400	3.5	0.80	77	4.8	2.2	2.2	2.5	10	33	16
	1.9	2,860	4.3	0.83	77	5.4	2.2	2.1	2.7	6		
RN100L21K	2	1,415	4.5	0.86	77	5.6	2.0	1.9	2.5	14	47	29
	2.4	2,880	4.9	0.93	77	6.8	2.2	2.0	3.0	8		
RN100L21	2.6	1,400	5.8	0.83	78	5.1	2.3	2.1	2.8	18	55	31
	3.1	2,880	6.4	0.90	78.5	6.8	2.5	2.0	3.3	10		
RN112M21	3.7	1,415	8.1	0.82	79.5	4.8	2.2	2.2	2.4	25	120	40
	4.4	2,880	9.2	0.89	77.5	6.1	2.5	2.1	3.0	15		
RN132S21	4.7	1,450	10.2	0.81	84	6.3	2.0	2.0	3.0	31	180	60
	5.9	2,925	11.8	0.89	81	7.1	2.2	1.9	3.6	19		
RN132M21	6.5	1,450	13.4	0.83	84	6.5	2.3	2.1	3.2	43	230	62
	8	2,925	15.4	0.90	83	7.5	2.2	2.0	3.6	26		
RN160M21	9.3	1,460	18.5	0.82	88	6.4	2.4	1.8	2.8	61	430	97
	11.5	2,935	22	0.90	84	7.5	2.3	1.6	3.3	37		
RN160L21	13	1,460	24.8	0.85	89	7.4	2.7	2.2	3.2	85	550	110
	17	2,935	31.4	0.91	86	7.5	2.4	1.4	3.6	55		
RN180L21B6	18	1,470	33.5	0.84	92	6.9	2.3	2	2.7	117	1,350	185
	21.5	2,950	40.3	0.87	88	7.7	2.5	1.9	3.1	70		
RN200L21B7	26	1,470	48	0.86	91	6.4	2.1	1.7	2.6	169	2,450	225
	31	2,945	55.3	0.91	88	7.5	2.2	1.7	3.1	101		
RN225S21B0	32	1,475	58	0.86	95.5	7.2	2.4	2.1	2.9	207	4,270	300
	38	2,955	70	0.89	88	7.5	2.1	1.6	3.2	123		
RN225M21B3	38	1,480	70	0.85	92.5	8.4	2.9	2.4	3.5	245	5,410	330
	45	2,970	83	0.88	89	9.2	2.8	1.8	3.8	145		
RN250M21B3	46	1,480	83	0.86	92.5	6	2.3	1.8	2.2	297	7,830	440
	55	2,960	96	0.92	90	6.5	2.1	1.5	2.6	177		
RN280S21B3	63	1,482	114	0.85	94	7.3	2.4	2.1	2.9	406	13,855	610
	75	2,968	138	0.86	90.5	8.1	2.4	1.5	3.4	241		
RN280M21B3	73	1,485	130	0.87	94.5	7.2	2.4	1.4	2.7	469	16,770	660
	87	2,970	150	0.92	91.5	8.7	2.3	1.4	3.1	280		
RN315S21C0	85	1,490	154	0.85	94	6.4	2	1.8	2.2	547	22,000	830
	100	2,970	180	0.88	91	7	1.9	1.4	2.8	322		
RN315M21C3	100	1,487	182	0.86	95	6.3	2.2	1.6	2.2	642	28,500	910
	120	2,970	210	0.9	92	7	2	1.1	2.8	386		

Pole-changing Motors Electrical Data

Outputs when in continuous use (S1) and at a maximum environmental temperature of 40°C.

Outputs on demand with regard to deviating environmental temperatures, intermittent operation S2, S3, etc., and deviating frequencies.

Housing size IEC type	Power kW	Rotational speed min ⁻¹	Nominal current at 400 V A	Power factor cos φ -	Efficiency %	Starting current Ia/In -	Starting torque Ma/Mn -	Saddle torque Mz/Mn -	Stall torque Mk/Mn -	Nominal torque Nm	Mass inertia J kgm ² × 10 ⁻⁴	Mass kg
6/4-pole synchronous rotational speed 1,000/1,500 min⁻¹ for constant torque application												
RN80M25	0.26	930	0.95	0.78	51	2.8	1.6	1.5	1.8	2.7	17	10
	0.4	1,430	1.25	0.73	63	3.8	1.7	1.7	2.2	2.7		
RN90S25	0.38	940	1.34	0.72	57	3.1	1.4	1.1	1.7	3.9	24	14
	0.65	1,440	0.77	0.77	69	4.4	1.7	1.6	2.1	4.3		
RN90L25	0.55	940	1.75	0.75	61	3.1	1.7	1.7	2.1	5.6	33	16
	0.9	1,430	2.40	0.83	66	4.1	1.6	1.4	2.4	6.0		
RN100L25K	0.9	900	2.70	0.77	63	3.0	1.6	1.5	1.9	9.5	47	29
	1.3	1,415	3.20	0.82	72	4.4	1.6	1.5	2.0	8.8		
RN100L25	1.1	915	3.3	0.73	66	3.3	1.9	1.9	2.3	12	54	31
	1.7	1,420	4.2	0.79	74	4.9	2.1	2.1	2.7	11		
RN112M25	1.5	950	4.2	0.73	70	3.7	1.7	1.7	2.2	15	120	41
	2.3	1,460	5.7	0.73	79	6.1	2.2	1.9	3.4	15		
RN132S25	2	965	4.8	0.79	76	4.5	1.6	1.6	2.3	20	180	57
	3.1	1,470	6.7	0.82	82	6.2	1.8	1.4	2.6	20		
RN132M25	2.8	965	7.0	0.77	75	5.2	1.8	1.6	2.3	28	230	65
	4.3	1,465	9.6	0.79	82	7.0	2.0	1.9	3.4	28		
RN160M25	4.3	970	10.4	0.74	81	5.2	1.8	1.2	2.0	42	430	97
	6.6	1,470	13.5	0.83	86	7.0	2.1	2.0	2.8	43		
RN160L25	6.3	975	15	0.73	83	5.4	2.1	1.4	2.6	62	600	110
	9.5	1,470	18.1	0.86	88	7.2	2.2	2.1	2.8	62		
RN180L25C6	11	955	22.5	0.80	87.5	4.6	2.0	1.8	2.1	110	1,050	180
	16.5	1,465	32	0.83	90	5.6	1.8	1.6	2.7	108		
RN200L25C7	16	970	32.5	0.79	89.5	5.4	2.2	2.0	2.4	158	1,510	230
	24	1,470	47	0.81	91	6.3	1.9	1.6	2.8	156		
RN225M25C3	25	975	49	0.82	90	5.8	2.4	2.1	2.2	245	4,600	330
	37	1,470	67	0.87	91	6.0	1.9	1.8	2.3	240		
RN250M25C3	32	980	61	0.83	91	5.8	2.4	1.9	2.3	312	5,200	410
	47	1,475	83	0.88	92.5	6	1.9	1.5	2.4	304		
RN280S25C0	45	980	84	0.84	92	5.7	2.3	1.8	2	438	12,200	610
	66	1,480	118	0.87	92.5	6.6	2	1.6	2.4	426		
RN280M25C3	54	980	100	0.85	92	5.8	2.4	1.9	2	526	14,800	660
	80	1,480	142	0.88	93	6.6	2.1	1.8	2.5	516		
RN315S25C3	62	985	116	0.84	92.5	5.4	2.2	1.7	1.9	601	26,800	830
	92	1,485	166	0.86	93.5	6.2	1.8	1.5	2.2	592		
8/4-pole synchronous rotational speed 750/1,500 min⁻¹ Δ/YY for constant torque application												
RN71M23	0.09	670	0.75	0.56	31	1.7	2.0	1.8	2.0	1.3	7.7	7
	0.18	1,410	0.60	0.70	62	3.5	2.0	1.9	2.2	1.2		
RN80M23	0.18	700	1.40	0.52	38	2.0	2.7	2.6	2.6	2.5	17	10
	0.37	1,400	0.90	0.80	71	4.3	2.2	2.2	2.3	2.5		
RN90S23	0.35	675	1.20	0.71	56	2.5	1.5	1.5	1.6	5.0	23	14
	0.5	1,365	1.40	0.79	61	3.0	1.4	1.4	1.7	3.5		
RN90L23	0.5	690	1.70	0.68	62	2.8	1.7	1.6	2.1	6.9	31	16
	0.7	1,410	2.10	0.75	66	3.4	1.8	1.8	2.4	4.7		
RN100L23	0.9	680	2.80	0.70	67	3.0	1.8	1.7	1.9	12.6	63	27
	1.5	1,360	3.50	0.90	69	3.7	1.5	1.5	2.0	11		
RN112M23	1.4	700	4.10	0.72	68	3.6	1.4	1.4	1.8	19.0	130	34
	1.9	1,430	4.40	0.87	72	4.8	1.2	1.0	1.8	13		
RN132S23	1.8	720	6.30	0.57	72	4.3	2.0	1.9	2.6	24	180	57
	3.6	1,430	7.2	0.90	81	5.4	1.6	1.3	2.4	24		
RN132M23	2.5	720	8.8	0.58	71	3.9	2.4	2.1	2.9	33	230	65
	5	1,440	9.9	0.89	82	5.6	1.6	1.4	2.0	33		
RN160M23	3.5	725	11.6	0.56	78	4.0	2.1	1.9	2.3	46	430	94
	7	1,450	13.2	0.89	86	5.7	1.7	1.3	2.3	46		
RN160L23	5.6	725	17.4	0.59	79	4.2	2.3	1.8	2.4	74	600	112
	11	1,450	21.0	0.90	85	5.2	1.8	1.3	2.0	72		
RN180L23B6	11	730	27.5	0.66	87	4.0	2.1	2.1	2.7	144	2,300	178
	18	1,465	34.0	0.87	88	5.6	2.1	1.8	2.7	117		
RN200L23B7	17	732	39.0	0.72	87.5	6.2	2.7	2.5	3.0	222	3,700	235
	27	1,465	46.5	0.93	90	7.0	2.3	1.7	3.0	176		
RN225S23B0	22	728	46.5	0.77	88.5	5.0	2.2	1.8	2.3	289	5,800	300
	32	1,462	56.0	0.92	90	7.3	2.2	1.6	2.4	209		
RN225M23B3	25	725	53	0.78	89	5.2	2.3	2	2.4	329	6,600	330
	37	1,465	64	0.92	90.5	6.6	2.3	1.8	2.5	241		
RN250M23B3	32	730	66	0.77	90	5.4	2.3	2	2.3	419	11,000	435
	47	1,470	81	0.92	91	7	2.3	1.7	2.5	305		
RN280S23B0	38	735	77	0.78	91.5	6.2	2.3	2.2	2.4	493	14,000	550
	56	1,475	95	0.92	92.5	7	2	1.6	2.5	363		
RN315S23B0	56	740	114	0.77	92.5	6	1.9	1.7	2.3	723	24,000	740
	82	1,480	140	0.92	92.5	7	1.7	1.4	2.4	529		
RN315M23B3	78	740	162	0.75	93.5	7	2.5	2.3	2.8	1,007	34,600	850
	115	1,485	196	0.9	94	7.5	2.6	1.6	3	740		
RN315L23B6	92	742	178	0.86	93.5	5.5	1.7	1.4	2.1	1,184	36,000	990
	135	1,483	228	0.92	93	7.5	1.3	1.2	2.2	850		

Pole-changing Motors Electrical Data

Outputs when in continuous use (S1) and at a maximum environmental temperature of 40°C.

Outputs on demand with regard to deviating environmental temperatures, intermittent operation S2, S3, etc., and deviating frequencies.

Housing size IEC type	Power kW	Rotational speed min ⁻¹	Nominal current at 400 V A	Power factor cos φ -	Efficiency %	Starting current Ia/In -	Starting torque Ma/Mn -	Saddle torque Mz/Mn -	Stall torque Mk/Mn -	Nominal torque Nm	Mass inertia J kgm ² 10 ⁻⁴	Mass kg
4/2-pole synchronous rotational speed 1,500/3,000 min⁻¹ Y/YY for quadratic torque application												
RN80M21K-V	0.15	1,400	0.39	0.85	65	3.8	1.8	1.8	2.0	1.0	14	9
	0.7	2,740	1.76	0.92	63	4.0	1.6	1.6	1.8	2.4		
RN80M21-V	0.25	1,385	0.61	0.88	67	3.8	1.8	1.8	2.0	1.7	17	10
	0.95	2,780	2.40	0.85	67	4.2	1.9	1.9	2.0	3.3		
RN90S21-V	0.33	1,430	0.78	0.83	74	5.2	2.3	2.8	2.8	2.2	24	14
	1.4	2,840	3.50	0.80	71	4.8	2.2	2.7	2.7	4.7		
RN90L21-V	0.5	1,420	1.10	0.85	76	5.1	2.3	2.5	2.5	3.4	33	16
	2	2,850	4.60	0.84	75	5.0	2.0	2.5	2.5	6.7		
RN100L21K-V	0.65	1,420	1.40	0.87	79	5.2	1.9	2.1	2.1	4.4	47	29
	2.5	2,840	5.20	0.93	76	5.9	2.0	1.7	2.3	8.4		
RN100L21-V	0.8	1,430	1.7	0.86	80	5.6	2.3	2.0	2.5	5.3	55	31
	3.1	2,870	6.2	0.93	78	7.1	2.4	2.2	3.1	10.0		
RN112M21-V	1.1	1,445	2.4	0.80	82	5.4	2.1	2.0	3.1	7.3	120	39
	4.4	2,885	9.2	0.89	78	6.2	2.2	2.1	3.0	15		
RN132S21-V	1.45	1,465	3.1	0.81	83	6.7	2.3	2.3	3.5	10	180	60
	5.9	2,925	11.9	0.89	81	7.1	2.1	1.9	3.3	19		
RN132M21-V	2	1,460	4.1	0.83	84	7.1	2.3	2.2	3.7	13	230	62
	8	2,925	15.5	0.90	83	7.5	2.2	2.0	3.6	26		
RN160M21-V	2.9	1,465	5.6	0.87	87	5.9	2.0	1.8	2.6	19	430	97
	11.5	2,930	21.0	0.91	86	6.7	2.2	1.6	2.8	38		
RN160L21-V	4.3	1,460	8.7	0.82	87	5.5	2.0	1.9	2.8	28	550	110
	17	2,920	30.7	0.92	87	7.4	3.0	1.4	3.0	56		
RN180L21B6-V	5.8	1,475	10.8	0.84	91.5	6.5	1.8	1.4	2.3	38	1,350	180
	21.5	2,945	40	0.88	88	7.7	2.2	1.6	3.1	70		
RN200L21B7-V	8.4	1,475	15	0.88	91	6.5	2.1	1.5	2.6	54	2,450	225
	31	2,950	56	0.91	88.5	7.5	2.1	1.6	3.1	100		
RN225S21C0-V	10.5	1,475	19	0.88	90.5	6	1.7	1.4	2.2	68	4,270	300
	38	2,950	67	0.93	88.5	7	1.8	1.3	2.7	123		
RN225M21C3-V	13	1,480	23.5	0.86	92	7.5	2.8	2.2	3.1	84	5,410	330
	45	2,965	83	0.88	89	8.2	2.6	1.9	3.4	145		
RN250M21C3-V	15	1,475	26.5	0.89	92.5	6.4	1.9	1.7	2	97	7,830	440
	55	2,960	96	0.92	90	6.5	2	1.5	2.6	177		
6/4-pole synchronous rotational speed 1,000/1,500 min⁻¹ for quadratic torque application												
RN80M25K-V	0.12	940	0.50	0.74	46	2.8	1.7	1.5	1.8	1.2	14	9
	0.4	1,430	1.38	0.72	58	4.0	1.7	1.7	2.0	2.7		
RN80M25-V	0.18	930	0.73	0.67	53	2.5	1.5	1.4	1.8	1.8	17	10
	0.55	1,420	1.62	0.76	65	4.0	2.0	2.0	2.3	3.7		
RN90S25-V	0.29	950	1.05	0.70	57	3.1	1.5	1.4	2.0	2.9	24	14
	0.8	1,420	2.10	0.80	68	4.1	1.6	1.6	2.3	5.4		
RN90L25-V	0.38	955	1.33	0.71	58	3.0	1.7	1.5	1.8	3.8	33	16
	1.1	1,430	2.65	0.82	73	4.5	1.9	1.9	2.5	7.3		
RN100L25K-V	0.6	940	1.90	0.70	66	3.5	1.9	1.8	2.4	6.1	49	29
	1.7	1,400	4.00	0.82	75	4.6	2.0	2.0	2.4	12		
RN100L25-V	0.75	945	2.20	0.80	61	3.2	1.3	1.2	2.0	7.6	54	31
	2.1	1,400	4.70	0.88	74	4.5	1.9	1.9	2.3	14		
RN112M25-V	0.9	975	3.10	0.61	69	4.5	2.3	2.1	2.8	9	120	41
	3	1,450	6.8	0.80	80	6.1	2.1	2.0	2.5	20		
RN132S25-V	1.2	975	3.5	0.69	72	5.1	1.9	1.5	2.6	12	180	57
	3.9	1,460	8.4	0.83	81	6.1	1.7	1.7	3.1	26		
RN132M25-V	1.7	975	4.6	0.69	77	5.1	2.1	2.0	3.2	17	230	65
	5.4	1,460	11.2	0.83	84	6.6	2.2	1.9	3.0	35		
RN160M25-V	2.5	980	6.5	0.70	79	5.6	1.9	1.5	2.5	24	430	97
	7.2	1,470	14.0	0.84	88	7.5	2.2	2.2	3.4	47		
RN160L25-V	3.7	975	9.2	0.75	78	4.1	1.5	1.2	2.4	36	600	110
	12	1,470	23.2	0.84	89	7.5	2.7	2.3	3.1	78		
RN180M25C3-V	5.5	960	11.8	0.81	83	4.4	1.7	1.6	2.0	55	820	155
	16	1,465	31.0	0.83	90	5.7	1.8	1.7	2.6	104		
RN180L25C6-V	6.5	960	13.5	0.82	84	4.7	1.7	1.6	2.0	65	1,050	180
	19	1,460	36.0	0.84	90.5	5.5	1.7	1.6	2.4	124		
RN200L25C7-V	9.5	975	19.5	0.81	87	5.6	2.1	2.0	2.4	93	1,510	230
	26	1,470	51.0	0.81	91.5	6.0	2.0	1.9	3.0	169		
RN225S25C0-V	12	980	24.5	0.82	86.5	5.7	2.3	1.8	2.1	117	2,950	300
	34	1,465	63	0.86	91	5.6	1.7	1.7	2.3	222		
RN225M25D3-V	14.5	980	28.5	0.83	88	5.6	2.2	1.9	2.1	141	3,780	340
	40	1,470	72	0.85	92.5	5.8	1.9	1.6	2.3	260		
RN250M25C3-V	18	980	34	0.86	89	4.9	2	1.8	2	175	4,470	380
	52	1,475	91	0.88	93.5	5.9	2	1.8	2.7	338		
RN280S25C0-V	25	984	47	0.86	89.5	5	2.1	1.6	1.9	337	11,900	540
	70	1,480	124	0.88	92.5	6.2	2.2	1.6	2.6	452		
RN280M25C3-V	30	984	59	0.86	90.5	5.5	2.5	2	2	291	13,900	580
	82	1,480	156	0.86	93	6.6	2.4	1.9	2.8	529		

Pole-changing Motors Electrical Data

Outputs when in continuous use (S1) and at a maximum environmental temperature of 40°C.

Outputs on demand with regard to deviating environmental temperatures, intermittent operation S2, S3, etc., and deviating frequencies.

Housing size IEC type	Power kW	Rotational speed min ⁻¹	Nominal current at 400 V A	Power factor cos φ -	Efficiency %	Starting current Ia/In -	Starting torque Ma/Mn -	Saddle torque Mz/Mn -	Stall torque Mk/Mn -	Nominal torque Nm	Mass inertia J kgmx10 ⁻⁴	Mass kg
<i>8/4-pole synchronous rotational speed 750/1,500 min⁻¹ for quadratic torque application (fan application)</i>												
RN71M23-V	0.06	660	0.52	0.55	30	1.6	1.4	1.4	1.7	0.9	7.7	7
	0.3	1,355	0.86	0.74	67.5	3.6	2.4	2.0	2.1	2.1		
RN80M23K-V	0.1	680	0.57	0.61	42	2.3	1.7	1.7	1.9	1.4	14	9
	0.5	1,375	1.28	0.82	67	4.1	1.7	1.7	1.8	3.5		
RN80M23-V	0.15	685	0.70	0.60	48	2.4	1.5	1.5	1.8	2.1	17	10
	0.7	1,380	1.76	0.81	71	4.2	1.8	1.7	1.8	4.8		
RN90S23-V	0.22	700	1.15	0.62	44	2.3	1.1	1.1	1.8	3.0	24	14
	1	1,370	2.30	0.85	73	3.8	1.8	1.8	2.2	7.0		
RN90L23-V	0.33	700	1.70	0.53	50	2.4	1.4	1.4	2.2	4.5	33	16
	1.5	1,375	3.30	0.84	77	4.4	2.1	2.0	2.4	10		
RN100L23K-V	0.5	700	2.30	0.58	56	2.5	1.2	1.1	2.2	6.8	47	29
	2	1,400	4.30	0.82	78	4.8	2.1	2.0	2.7	14		
RN100L23-V	0.65	690	2.90	0.60	55	2.5	1.2	1.2	2.1	9	55	31
	2.5	1,390	5.4	0.86	78	4.8	2.2	2.0	2.6	17		
RN112M23-V	0.9	715	4.6	0.52	55	2.9	1.5	1.5	2.4	12	120	41
	3.6	1,430	7.9	0.82	81	5.9	2.3	2.2	2.8	24		
RN132S23-V	1.1	725	3.5	0.60	75	4.0	2.0	2.0	2.8	15	180	57
	4.7	1,460	10.4	0.80	82	6.1	1.7	1.6	2.8	31		
RN132M23-V	1.4	720	4.4	0.60	77	4.6	2.2	2.1	2.9	19	230	64
	6.4	1,455	13.3	0.83	84	6.8	1.9	1.9	3.0	42		
RN160M23K-V	1.5	730	4.8	0.55	79	4.0	1.9	1.6	2.6	20	430	95
	7	1,470	14.5	0.80	87	7.4	2.1	1.9	3.0	46		
RN160M23-V	2.2	725	6.2	0.63	81	3.8	1.8	1.6	2.6	29	430	95
	9.5	1,465	19.0	0.83	86	6.9	2.3	1.6	2.8	62		
RN160L23-V	3.3	730	9.2	0.63	82	4.4	2.1	1.7	2.3	43	600	114
	14	1,465	28.0	0.84	86	7.5	2.6	1.7	3.2	91		
RN180M23C3-V	4.5	725	12.6	0.63	81.5	3.6	1.4	1.3	2.0	59	1,170	155
	16	1,465	31.0	0.84	88.5	6.8	2.2	1.7	3.1	104		
RN180L23C6-V	5	725	14.2	0.62	82.5	3.7	1.6	1.4	2.1	66	1,440	180
	18.5	1,470	35	0.85	90	7.2	2.4	2	3.3	120		
RN200L23C7-V	7.5	730	21.5	0.6	85	4.3	2.1	2	2.5	98	1,910	220
	28	1,465	52.8	0.86	91	7.3	2.7	2.5	2.9	182		
RN225S23C0-V	9.5	740	26	0.64	86	4.3	2	1.6	2.3	123	4,470	295
	35	1,480	64	0.86	92.5	6.9	1.7	1.7	2.9	226		
RN225M23C3-V	11.5	735	30.5	0.62	80	4.5	1.9	1.7	2.2	149	4,860	330
	42	1,480	75	0.87	93	6.9	2.4	2.1	3	272		
RN250M23C3-V	14.5	740	38	0.62	88.5	4	2	1.5	1.8	187	8,560	430
	52	1,480	94	0.86	93.5	6.8	2.5	2.1	2.6	335		
RN280S23C0-V	19	740	49	0.62	90.5	4	1.5	1	1.6	245	11,900	530
	70	1,480	124	0.86	94	6.3	2	1.8	2.5	451		
RN280M23C3-V	23	740	58	0.63	91	4.2	1.9	1.2	1.8	296	17,100	665
	83	1,485	146	0.87	94.5	7.2	2.2	2	2.7	534		
RN315M23B3-V	30	745	79	0.6	92	5.7	2.3	1.6	2.4	385	30,380	910
	115	1,488	212	0.84	95.5	8.4	2.7	2.3	3	738		
RN315L23C6-V	35	745	98	0.56	92.5	4.9	2.2	1.8	2.1	449	36,000	990
	140	1,490	255	0.84	95	7.5	2.8	2.5	2.8	900		

Brake Motors and Backstop

The brake selection depends greatly on the application. The applications can be very different. A 'holding brake' might be required for certain applications. This brake is not used for dynamic braking (full speed braking) but is engaged after the motor coasted down and whilst stationary. This is often required for electric motors with large moment of inertia attached on the shaft. In these situations the rotating energy would be converted into a lot of heat during dynamic (full speed) braking.

The correct brake selection can be made after consultation with the motor/brake supplier or manufacturer.

The following diagram provides an overview of the different types of brakes that can be mounted on rotor nl® electric motors.

The overview shows brake options that are available. Please contact our trained staff for the correct brake selection.

Housing size	Flange dimensions	Brake options		
		IP55/56/65/Ex-nA	IP 67 marine brake	Ex-d brakes
63	A140	4		
71	A140	8		8
	A160			
80	A160	16		22
	A200	10/25		
90	A160	16		22
	A200	25		
100	A200	32/60		40
	A250	50*		
112	A250	32/50*/60		60
132	A250	100		150
	A300	100, 160**		
160	A300	150/160**/250		180
	A350	160*		
180	A300	250	250/300/400	355
	A350		250/400	
200	A300		250/300/400	460
	A400		250/300/400/630	
225	A350	500	400/630	460
	A400		400/630/1,000	
	A450		400/630/1,000	
250	A450		630/1,000	1,000
	A550		630/1,000	
280	A450		1,000/1,600	1,200
	A550		1,000/1,600	
315	A550			
	A660		2,500/4,000*	
	A800		2,500/4,000/6,300/10,000*	
355				
400	A800		2,500/4,000/6,300/10,000	
450				

IP 65 and Ex-d brakes are independent of the flange dimensions and apply only to each housing size

*Flange is machined for mounting

Section 5

Rotor B.V. Services



70	Maintenance and Operating Instructions
71	Bearings and Lubrication
73	Stock Colours and Coating
74	Rotor nl® Product Delivery Schedule
74	Advice and Training
74	Technical Training Courses

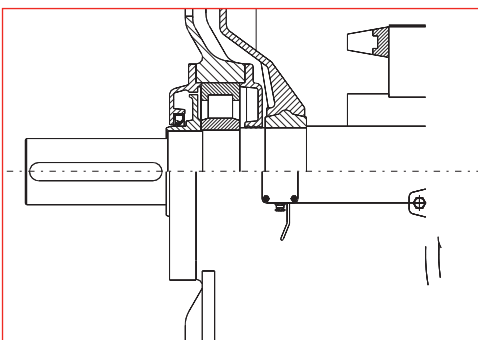

The following pages contain information about the services provided by Rotor B.V., including the warranty conditions and the delivery schedule.

Safety

All electric motors must be installed by qualified engineers. The electrical connection and the commissioning may only be performed by a qualified installer in accordance with the applicable criteria, regulations and directives. The manufacturer will not be held responsible for damages resulting from ill installation and/or use.

Storage

Warehousing

Electric motors must be stored in a dry, vibration-free place. Cable entries and deep fixing holes in FT (B14) flanges must be sealed. Electric motors that have been out of operational for prolonged period of time must have their insulation resistance checked before commissioning. Motor winding should be dried should the insulation resistance be lower than 30 MOhm (measured for at 1,000 V).

Installation and fitting

The fitting and installation of an electric motor must correspond to the motor mounting as specified on the motor's rating plate. The motor should be dry before installation. During the installation the motor must be positioned in such a way that an uninterrupted supply of sufficient volume of cooling air is available for the motor at all times. The maximum length of the flange mounting bolts is limited to 2.5 x the bolt diameter for flange mounted motors with FT (B14) flanges (to prevent damage of the winding).

Power transmission

The mechanical power of the electric motor can usually be transmitted to the driven equipment through flexible coupling, a V-belt or a belt transmission. An accurate shaft alignment will increase the service life of the bearings as well as other motor parts. In case of electric motor integration in the driven equipment the installer/manufacturer of the driven equipment must satisfy himself that the type of the electric motor is suitable for the specific application. The transmission components must be securely fastened on the motor's shaft. The electric motors are balanced with a half key and marked with a letter H on the rating plate and/or the shaft end.

Tightening torques

The tightening bolts and nuts torque requires a special attention. During the motor installation the bolts and nuts must be tightened manually using standard manual tools until the spring washer is depressed and is flat. The maximum permissible torque related to the bolts and nuts used is not relevant for motor installation. Over-tightening can damage the electric motor construction and compromise its integrity. The use of (large) torque wrenches is not recommended. The same principle applies for the bolts and nuts on the terminal board. Correct star/delta (where applicable) configuration must be established. All nuts must be properly tightened but not overtightened. After approximately 300 operational hours all installation fasteners and electrical connections must be checked.

Electrical connection

The electrical connection of an electric motor must meet all applicable local regulations. Thermal protection (if fitted) must limit the risk of overloading of the motor. The use of a thermistor relay is recommended for PTC thermistors (if fitted). Standard electric motors can be used for both directions of rotation. The direction of rotation at standard three-phase motors can be changed by swapping any two incoming phase leads. A low-noise execution is available for one direction of rotation (these motors have an arrow marked on the endshield).

Frequency inverter

No restrictions usually apply for inverter duty motors for variable torque applications when the speed control range is between 30% and 120% of the nominal speed (at 50 Hz). The torque reduction applies for constant torque applications if the motor is not equipped with force ventilation. For more information and for speed control outside the above control range please contact the electric motor manufacturer.

General maintenance

Standard rotor nI® electric motors are practically maintenance-free. Any maintenance is limited to the following:

- Cleaning the motor surface and the cooling air openings to ensure sufficient cooling
- Re-lubrication and/or replacement of 2Z bearings.

Bearings in general

The bearings used in standard rotor nI® motors are listed in Table 1.

The motors have been equipped with C3 type of bearings as standard. Special grease must be used for extremely low or extremely high temperatures.

Bearing lubrication - Closed bearings

Smaller electric motors sizes are fitted with closed bearings (2Z) lubricated for life. These bearings must, be replaced at the end of the service life (see Table 2). High temperature grease (i.e. 85°C) bearings are recommended for the replacement. The service life of these bearings is considerably longer than standard ball bearings with standard grease (70°C). Smaller sizes of rotor nI® electric motors are supplied with 2Z bearings with a WT (85°C) grease as standard. These are special bearings supplied by with a temperature range of -40°C to +160°C and a service life higher than the average lithium complex greases. It is recommended replacing 2Z bearings every 4 years to prevent contamination as a result of ambient humidity and air pollution.

Bearings and Lubrication

Open bearings with grease in bearing housing

Open bearings are used for larger electric motors sizes that have been fitted with ball bearings. The grease is based on lithium with mineral oil. These bearings can be re-lubricated many times. The old grease is collected in the used grease chamber of the bearing cap. Re-lubrication must take place whilst the electric motor is operating. The fact that the grease nipple and the grease canal may be both completely empty before the first re-lubrication must be taken into consideration. Certain degree of counter-pressure is felt through the grease gun during the re-lubrication indicating the amount of grease that have been applied during re-lubrication The used grease chamber need removing after a number of re-lubrications The used grease removing is often performed when bearings are replaced. If bearings are subject to light load and have a long residual life left, they probably only need cleaning, used grease needs removing, bearings and bearing caps need refilling with grease (grease filling: bearings 50% and bearing caps 30% of the free space). Ex-e and Ex-n electric motors with open bearings and a used grease chamber are supplied without a lubrication nipple.

Open bearings with used grease discharge

If the electric motors are equipped with an automatic used grease discharge, unlimited re-lubrication is possible. The automatic used grease discharge works on an oscillating wheel principle that discharges the surplus grease to the used grease chamber. Closed used grease chamber must be open for one hour after the re-lubrication whilst the motor is operating to ensure that the surplus grease can be discharged.

Re-lubrication period

The re-lubrication period depends on the rotating speed, the shaft load, ambient factors electric motor installation. Re-lubrication must be carried out in accordance with the recommendations of the bearing and grease supplier. General guidelines can be found in the re-lubrication table. The values specified in Table 3 are for general guidance only and apply for horizontal motors with bearings temperature 70°C (for normal load and ambient temperature). The re-lubrication period must be halved for vertical electric motors. The re-lubrication period must be halved for every run when the temperature was 15°C above the bearing nominal temperature. Longer re-lubrication period is sometimes recommended if motors run at low

temperatures - any re-lubrication period must not be longer than two times the recommended re-lubrication period. The re-lubrication period must be shortened when heavy shaft loads are applied.

Grease type

The rotor nl® electric motors that have been fitted with open bearings are supplied with a lithium based grease as standard. Grease types based on lithium with mineral base oil can be used for re-lubrication Good quality high temperature grease should be the preferred choice. If an electric motor is fitted with a special bearing and/or special grease (upon request), the bearing/grease information would be specified on the rating plate as well as the re-lubrication period.

Warranty

Warranty procedures and processes are in accordance with the general Terms and Conditions of Rotor B.V. currently in force at the time of the delivery.

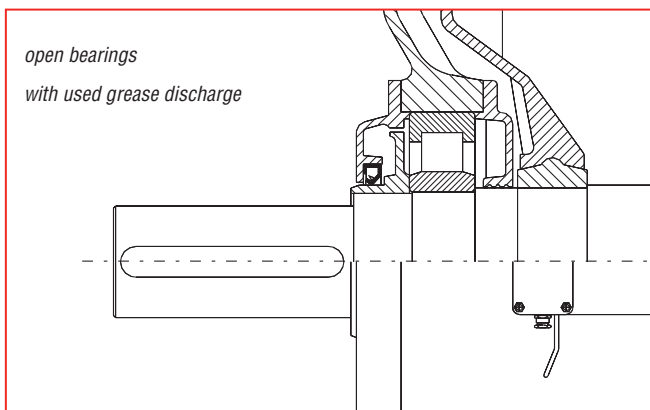

IEC housing size	Pole number	Bearing types	
		THE	NDE
RN56	all	6201-2Z/C3	6201-2Z/C3
RN63	all	6201-2Z/C3	6201-2Z/C3
RN71	all	6202-2Z/C3	6202-2Z/C3
RN80	all	6204-2Z/C3	6204-2Z/C3
RN90	all	6205-2Z/C3	6205-2Z/C3
RN100	all 5RN	6206-2Z/C3	6206-2Z/C3
RN100	all 6RN	6306-2Z/C3	6306-2Z/C3
RN112	all	6306-2Z/C3	6306-2Z/C3
RN132	all	6308-2Z/C3	6308-2Z/C3
RN160	all	6309-2Z/C3	6309-2Z/C3
RN180	all	6310-2Z/C3	6310-2Z/C3
RN200	5RN 2,2/4	6312/C3	6312/C3
RN200	all 6RN & 5RN 4,6,8	6312-2Z/C3	6312-2Z/C3
RN225	5RN 2	6213/C3	6213/C3
RN225	all 6RN & 5RN 4,6,8	6313/C3	6313/C3
RN250	5RN 2	6215/C3	6215/C3
RN250	all 6RN & 5RN 4,6,8	6315/C3	6315/C3
RN280	5RN 2	6216/C3	6216/C3
RN280	5RN 2	6217/C3	6217/C3
RN280	6RN 2	6315/C3	6315/C3
RN280	all 6RN & 5RN 4,6,8	6317/C3	6317/C3
RN315	5RN 2	6217/C3	6217/C3
RN315	6RN & 5RN 2	6316/C3	6316/C3
RN315	5RN 2	6219/C3	6219/C3
RN315	6RN & 5RN 4,6,8	6319/C3	6319/C3
RNN315	2	6218/C3	6218/C3
RNN315	4,6,8	6218/C3	6218/C3
RNN355	2	6218/C3	6218/C3
RNN355	4,6,8	6220/C3	6220/C3
RNN400	2	6218/C3	6218/C3
RNN400	4,6,8	6224/C3	6264/C3
RNN450	2	6220/C3	6220/C3
RNN450	4,6,8	6228/C3	6228/C3

Bearing	Grease service life in hours of closed bearings provided with WT grease ($T_{ref} 85^{\circ}C$) at a bearing temperature of $70^{\circ}C$, at rotational speed in min^{-1}							
	3,600	3,000	1,800	1,500	1,200	1,000	900	750
6201 2Z/C3	40,000	40,000	40,000	40,000	40,000	40,000	40,000	40,000
6202 2Z/C3	40,000	40,000	40,000	40,000	40,000	40,000	40,000	40,000
6204 2Z/C3	40,000	40,000	40,000	40,000	40,000	40,000	40,000	40,000
6205 2Z/C3	40,000	40,000	40,000	40,000	40,000	40,000	40,000	40,000
6206 2Z/C3	40,000	40,000	40,000	40,000	40,000	40,000	40,000	40,000
6306 2Z/C3	40,000	40,000	40,000	40,000	40,000	40,000	40,000	40,000
6308 2Z/C3	32,000	40,000	40,000	40,000	40,000	40,000	40,000	40,000
6309 2Z/C3	26,000	36,000	40,000	40,000	40,000	40,000	40,000	40,000
6310 2Z/C3	22,000	32,000	40,000	40,000	40,000	40,000	40,000	40,000
6312 2Z/C3	18,000	24,000	36,000	40,000	40,000	40,000	40,000	40,000

The grease service life is the time where still 99% of the bearings are sufficiently lubricated. This time is twice as long at 90%.
The grease service life must be halved with regard to standard (MT) grease filling with a reference temperature of $70^{\circ}C$.
The grease service life must be halved for electric motor set-ups on a vertical shaft.

Bearing	Grease (grams)	Relubrication in hours at open bearings and rotational speed in min^{-1}							
		3,600	3,000	1,800	1,500	1,200	1,000	900	750
6312/C3	20	4390	6050	11500	13500	15800	17600	18600	20100
6213/C3	14	4620	6310	11800	13800	16100	17800	18800	20300
6313/C3	23	3770	5330	10600	12600	15000	16900	17900	19500
6215/C3	16	3770	5330	10600	12600	15000	16900	17900	19500
6315/C3	30	2780	4140	9140	11100	13600	15500	16600	18300
6216/C3	18	3240	4700	9860	11900	14300	16200	17200	18900
6316/C3	33	2390	3650	8470	10500	12900	14900	15900	17700
7217	10	6250	8120	13700	15600	17800	19400	20300	21600
6217/C3	21	2780	4140	9140	11100	13600	15500	16600	18300
6317/C3	37	2060	3210	7850	9820	12300	14200	15300	17200
6218/C3	24	2390	3650	8470	10500	12900	14900	15900	17700
6319/C3	45	1520	2500	6750	8650	11100	13100	14200	16100
6220/C3	31	1770	2830	7280	9220	11700	13700	14800	16600
6320/C3	51	1240	2110	6100	7950	10400	12400	13500	15400
6322/C3	60	870	1570	5110	6860	9220	11200	12400	14300
6224/C3	43	1010	1780	5510	7310	9690	11700	12900	14800
6226/C3	46	786	1440	4860	6580	8910	10900	12100	14000
NU213/C3	14	1810	2590	7370	9310	11800	13800	14900	16700
NU215/C3	16	1340	2250	6330	8210	10600	12600	13800	15700
NU310/C3	15	2650	3970	8910	10900	13400	15300	16400	18100
NU312/C3	20	1680	2710	7100	9020	11500	13500	14600	16500
NU315/C3	30	850	1540	5040	6790	9140	11100	12300	14300
NU216/C3	18	1060	1860	5650	7470	9860	11900	13000	15000
NU316/C3	33	675	1270	4500	6180	8470	10500	11600	13600
NU217/C3	21	850	1540	5040	6790	9140	11100	12300	14300
NU317/C3	37	540	1050	4020	5620	7850	9820	11000	13000
NU319/C3	45	340	720	3200	4650	6750	8650	9800	11800
NU322/C3	60	-	360	2110	3280	5110	6860	7950	9920

Relubrication times are based on bearing and grease manufacturer data determined in accordance with the last known method.
The relubrication times must be halved for electric motors that are set up on a vertical shaft.
The relubrication times must be halved for each $15^{\circ}C$ increase with regard to grease temperatures higher than the grease reference temperature.

Note:

The combinations of ICE/DIN housing sizes and bearings are in part dependent on the electric motor type and application. Also consult the binding data as stated in the documentation of the specific motor type. Special bearing designs can also be supplied on request.

D.E. = drive end

N.D.E. = non-drive end

2Z: (SKF) coding, two-sided (metal) closed bearing. (Protection plates on both sides of the bearing).

C3: coding for the (radial) bearing clearance class.

SO 12944	specific conditions	application examples
C1		urban areas, low pollution, heated buildings and neutral atmospheres
C2	light condensing	unheated buildings where condensation may occur, warehouses and sports halls
	low humidity	atmospheres with low pollution, rural, dry area with little air pollution
C3	high humidity	offices with high humidity and some air pollution, laundromats, breweries and dairy companies
	high humidity, moderate pollution	urban and industrial atmospheres with moderate CO ₂ pollution. coastal areas with low salinity
C4		Industrial/coastal areas and chemical companies
C5	high humidity, moderate pollution	Chemical plants, swimming pools and ports.
	high humidity (SO ₂ = 30 mg/m ³)	Industrial areas with high humidity and aggressive atmosphere.
	Salty environment	marine, offshore and coastal areas and areas with high salinity, such as; offshore windmills and wells.

Stock colours

The following paint colours are standard stock colours. Upon request any electric motor can be sprayed/painted in any of these colours. Rotor operate its own spray shop where special anti-corrosion coatings can be applied. These coatings consist of several layers of paint with different characteristics, which, in the correct combination, are resistant to a number of corrosive agents such as seawater, chemical fumes etc.



RAL 1007	Daffidol yellow
RAL 1015	Light ivory
RAL 2000	Yellowish orange
RAL 2002	Blood orange
RAL 2004	Pure orange
RAL 2008	Bright red orange
RAL 2009	Traffic orange
RAL 3001	Signal red
RAL 5001	Green blue
RAL 5002	Ultramarine blue
RAL 5005	Signal blue
RAL 5007	Brilliant blue
RAL 5009	Azure blue
RAL 5010	Gentian blue
RAL 5012	Light blue
RAL 5015	Sky blue
RAL 5017	Traffic blue
RAL 6028	Pine green
RAL 7012	Basalt grey
RAL 7016	Anthracite grey
RAL 7021	Black grey
RAL 7030	Stone grey
RAL 9003	Signal white
RAL 9005	Jet black
RAL 9010	Pure white
RAL 9016	Traffic white

The colours shown here are an approximation of the actual colours.

Rotor nl® Products Delivery Schedule

- Three-phase squirrel-cage electric motors 0.04—1000 kW
- Special electric motors for:
 - Offshore and Marine industry
 - Oil & Gas industry
- Special executions:
 - High IP ratings: IP 55/56/67/68
 - ATEX motors derived from the standard range
 - ATEX pressure-tight electric motors Ex-d(e)-IIC-T4 to 250 kW
 - Single-phase squirrel-cage electric motors
 - Brake motors up to frame size IEC450

Advice and Training

- Application consultancy
 - electric motor drive technology
 - project and/or location orientated

Technical Training Courses

- Electric motor drive technology courses for OEMs and End Users



Strong together!



A Regal Brand



rotor nl[®]

Rotor B.V.

Mors 1-5, PO Box 45, 7150 AA Eibergen, The Netherlands
Tel. +31-(0)545 46 46 40, Fax +31-(0)545 47 50 65
info@rotor.nl, www.rotor.nl

December 2015

A Regal Brand



www.regalbeloit.com